



Applied Air®

INSTALLATION, OPERATION AND MAINTENANCE MANUAL FOR IFL SERIES COMFORT SYSTEMS

ATTENTION: READ THIS MANUAL AND ALL LABELS ATTACHED TO THE UNIT CAREFULLY BEFORE ATTEMPTING TO INSTALL, OPERATE OR SERVICE THESE UNITS! CHECK UNIT DATA PLATE FOR TYPE OF GAS AND ELECTRICAL SPECIFICATIONS AND MAKE CERTAIN THAT THESE AGREE WITH THOSE AT POINT OF INSTALLATION. RECORD THE UNIT MODEL AND SERIAL No.(s) IN THE SPACE PROVIDED. RETAIN FOR FUTURE REFERENCE.

FOR YOUR SAFETY

The use and storage of gasoline or other flammable vapors and liquids in open containers in the vicinity of this appliance is hazardous.

POUR VOTRE SÉCURITÉ

L'utilisation et l'entreposage d'essence ou d'autres liquides ou produits émettant des vapeurs inflammables dans des récipients ouverts à proximité de cet appareil est dangereux.



FOR YOUR SAFETY

If you smell gas:

1. Open Windows
2. Don't touch electrical switches.
3. Extinguish any open flame.
4. Immediately call your gas supplier.



POUR VOTRE SÉCURITÉ

Si vous sentez une odeur de gaz :

1. Ouvrez les fenêtres.
2. Ne pas actionner d'interrupteur.
3. Éteindre toute flamme ouverte.
4. Appelez immédiatement votre fournisseur de gaz.

WARNING: Improper installation, adjustment, alteration, service or maintenance can cause property damage, injury or death. Read the installation, operating and maintenance instructions thoroughly before installing or servicing this equipment.

AVERTISSEMENT: Une installation déficiente, de même qu'un mauvais réglage, modification, entretien ou maintenance peuvent occasionner des dommages matériels, corporels voire causer la mort. Lire attentivement les instructions d'installation, d'utilisation et d'entretien avant d'installer ou d'intervenir sur cet appareil.

WARNING

Install, operate and maintain unit in accordance with manufacturer's instructions to avoid exposure to fuel substances or substances from incomplete combustion which can cause death or serious illness. The state of California has determined that these substances may cause cancer, birth defects, or other reproductive harm.

INSTALLER'S RESPONSIBILITY

Installer Please Note: This equipment has been test fired and inspected. It has been shipped free from defects from our factory. However, during shipment and installation, problems such as loose wires, leaks or loose fasteners may occur. **It is the installer's responsibility to inspect and correct any problems that may be found.**



Applied Air®

4830 Transport Drive, Dallas, TX 75247 Phone: 214-638-6010 Fax: 214-905-0806

SECTION I – FOREWORD

As is the case with any fine piece of equipment, care must be taken to provide the proper attention to the operation and maintenance detail of this machine.

This manual of instructions has been prepared in order for you to become well acquainted with those details, and in doing so, you will be able to give your Packaged Comfort System the care and attention which any piece of equipment needs and deserves.

It is the customer and installation personnel responsibility to determine if the unit is equipped with all of the safety devices required for the particular application. Safety considerations include the accessibility of the unit to non-service personnel, the provision of electrical lockout switches, maintenance procedures, and automatic control sequences. Clearly mark all emergency shutoff devices.

Table of Contents

Section I: Foreword and Table of Contents	2
Section II: General Information	3
Section III: Installation	4
Section IV: Pre-Start Up	11
Section V: Unit Start Up	13
Section VI: Unit Shut Down	17
Section VII: Troubleshooting	17
Section VIII: Flue Gas Analysis	39
Section IX: Maintenance Schedule and Lubrication Requirements	40
Section X: Mestek Line Burner	45
Section XI: Circuit Analysis & Sequence and Burner Setup	46
Section XII: Thermistor Curve	47
Section XIII: Replacement Parts	47

IMPORTANT NOTICE

The factory assumes no responsibility for loss or damage in transit; therefore, you should protect yourself by following these instructions. Failure to do so is your responsibility.

BILL OF LADING

Save your bill of lading. It is a contract, and you will need it, provided you have to file a loss or damage claim. Remember, claims are outlawed after nine months.

LOSS IN TRANSIT

Before you sign for this shipment, check against the bill of lading, also the transportation company's delivery ticket. Make sure that you get the exact total of articles listed. Should the delivery ticket show more or less items than you are offered, then the carrier's agent must mark the difference on your freight bill before you sign.

VISIBLE DAMAGE IN TRANSIT

If something is damaged, accept the shipment only if the carrier's agent places a notation on your freight bill explaining the nature and extent of damage. Upon inspection of article, make claim to the delivering carrier.

CONCEALED DAMAGE IN TRANSIT

Sometimes transit damage is not noticed until the goods are unpacked. In such cases, notification to the carrier must be made within fifteen (15) days of receipt of shipment. In such cases, save the packages and packing material, then notify the transportation company at once, and request an inspection. When the inspector calls, have him make out and leave a "concealed" bad order report. He is obliged to give you one. Insist on it.

DISPOSITION OF DAMAGED ARTICLES

Never return damaged articles to us. They are the property of the transportation company when the claim is filed. They will give you disposition instructions.

PACKING

We comply with the packing requirements of the transportation companies, and your bill of lading proved that everything was in good condition when shipped. That bill of lading contract requires them to deliver in perfect condition.

SECTION II – GENERAL INFORMATION

A. Purpose

The purpose of this manual is to present a guide for proper installation, maintenance, and operation of the Packaged Comfort System, and supplement, **but not to replace**, the services of qualified field service personnel to supervise the initial start-up and adjustment of the unit. Persons without previous experience with large commercial and industrial heating and cooling equipment should not attempt the initial adjustment and checkout procedure, which is essential before such installations may be considered ready for operation. This manual should be made readily available to all operating personnel as an aid in troubleshooting and proper maintenance. Due to the custom nature of this equipment, not all possibilities are addressed in this manual. The customer or installer can obtain information from local sales representative or the factory.

Warning: Failure to comply with general safety information may result in extensive property damage, severe personal injury or death

B. Shipping

The basic IFL Series Comfort System is shipped completely assembled where shipping limitations allow. Optional accessories are assembled and shipped mounted and wired whenever possible within limitations of shipping and handling. Some optional accessories shipped separately may require field assembly. Any wired accessories, which have been disassembled for separate shipment, require no additional conduit or wire for field reassembly. All wire leads will be tagged for ease of reconnection in the field.

If the unit and/or accessories cannot be installed immediately, they should be stored in a clean dry environment. If this is not possible and the unit must be stored outdoors, it should be protected from the weather with tarpaulins or plastic coverings. Do not assume that simply covering a unit will keep insects, dust, and condensation out of the unit and critical components. Rotate the fan monthly. Prior to beginning installation of a unit that has been in storage for weeks or months, the unit and all components should be closely inspected.

Shipments are made F.O.B. Dallas, Texas by truck. The unit is securely strapped, tied, and blocked to prevent shipping damage. All shipments are checked by an inspector before they are accepted by the carrier. Parts that are shipped un-mounted are noted on the bill of lading. These parts, where feasible, are packaged and shipped with the unit. Upon receipt of shipment, all units should be checked against the bill of lading to insure all items have been received. All equipment (and any optional accessories) should be checked carefully for physical damage in the presence of the carrier's representative. If parts are missing or damage has occurred, you should request an inspection, and a claim should be filed immediately with the carrier.

All IFL Series Comfort Systems are given a complete operations test and control circuit checkout before shipment. Copies of the wiring diagram, piping diagram and bill of material are included with each unit shipped. If correspondence with the factory is necessary, please provide the unit model and serial number.

C. Optional Factory Service

Periodic service on any piece of mechanical equipment is necessary for efficient operation. A nationwide service support network is available to provide quick and dependable servicing of make-up air, heating, ventilating, or air handling types of equipment. The factory also offers start-up service, which includes the presence of a service engineer to supervise the initial start-up and adjustment of the equipment and provide instructions for the owner's maintenance personnel in proper operations and maintenance. Consult factory for quotations on periodic or start-up service.

D. Curb Mounted Units

Outdoor units can be supplied with an optional roof curb. The curb greatly facilitates installation thereby reducing installation costs. All connections to the unit: duct, piping, electrical power and control wiring can be made through the roof opening. The curb may be shipped prior to unit shipment. All curbs are shipped un-assembled from the factory.

Use extreme caution in handling the curb. Proper handling and positioning will assure a water-tight curb unit installation.

Re-check approval prints prior to installation. Be sure that there are no obstructions to ducting and that proper planning has been exercised in connection of piping and/or electrical services.

The curb assembly may be bolted or welded to either trusses or roof decking; however, connection to roof trusses is recommended. The curb is designed to carry the weight of the unit. Additional support is required for certain applications.

Placement of the curb is critical in squareness and leveling. Shims for leveling must be applied to the curb; application of shims to the unit will tend to destroy the sealing effect after installation. Make sure sealing tape is in place before unit is set. Be careful not to allow gaps where two pieces of sealing tape meet. A bubble level must be used in leveling process. Measure across diagonals to check for squareness. Allowable tolerance is 1/4" difference between diagonal measurements. Double-check approval prints before setting the unit.

Upon completion of setting the curb, apply roofing material and flashing as required.

On outdoor curb mounted installations, flash and seal the roof curb to prevent leakage. The cross section of factory provided curb is formed to accept wood nailing strip and insulation provided by others.

SECTION III – INSTALLATION

FOR CANADIAN INSTALLATIONS ONLY

1. All installations must conform with local building codes, or in the absence of local codes, with current CAN/CGA-B149-Installation Codes for Gas Burning Appliances and Equipment.
2. All electrical connections must be in accordance with Canadian Electrical Code, Part 1, CSA Standard C22.1.

All electrical connections must conform to the current edition of ANSI/NFPA No. 70 National Electrical Code and applicable local codes: in Canada, to the Canadian Electrical Code, Part 1, CSA Standard C22.1. The following recommendations are not intended to supplant any requirements of federal, state, or local codes having jurisdiction. Authorities having jurisdiction should be consulted before installations are made. Local codes may require additional safety controls and/or interlocks.

All installations in airplane hangers must be in accordance with current ANSI/NFPA No. 409. All installations in public garages must be in accordance with current NFPA No. 88A and NFPA No. 88B.

CAUTION: Do not install heating system in corrosive or flammable atmospheres! Premature failure of, or severe damage to the unit will result!

CAUTION: Heating system must not be installed in locations where air for combustion would contain chlorinated, halogenated or acidic vapors. If located in such an environment, premature failure of the unit will occur!

A. Handling The Equipment

The Packaged Comfort System has been designed for rigging and handling through the use of special lifting lugs installed on the base of each unit. As explained previously, the basic unit is designed for shipping in one piece where shipping limitations allow. Some optional accessories may require field mounting.

During lifting operations, slings or chains with hooks and I-beam spreader are recommended, see figure below. Lifting must be equal to all lugs furnished. The spreader bar (I-beam or equal) must be equal in length to the longest span between lifting points. Depending on sling length one or more spreaders are recommended. In no case should the lift be less than 80-degrees from horizontal or more than 30-degrees from threaded shank direction. When unloading and setting the unit, use the lifting points provided or move the equipment on rollers. Hooks, jacks, or chains must not be used around the casing, main control panel or exterior mounted controls.

During transit, unloading and setting of the unit, bolts and nuts may have become loosened, particularly in the pillow block ball bearing assemblies in the fan section. It is recommended that all nuts and setscrews be tightened. Turn fan shaft by hand to make certain that wheel does not rub against venturi, and that bearing setscrews are tight.

Open the cover on the electrical control box located on the unit and ensure that all connections are tight. Rotate fans monthly.

Packaged Unit Rigging

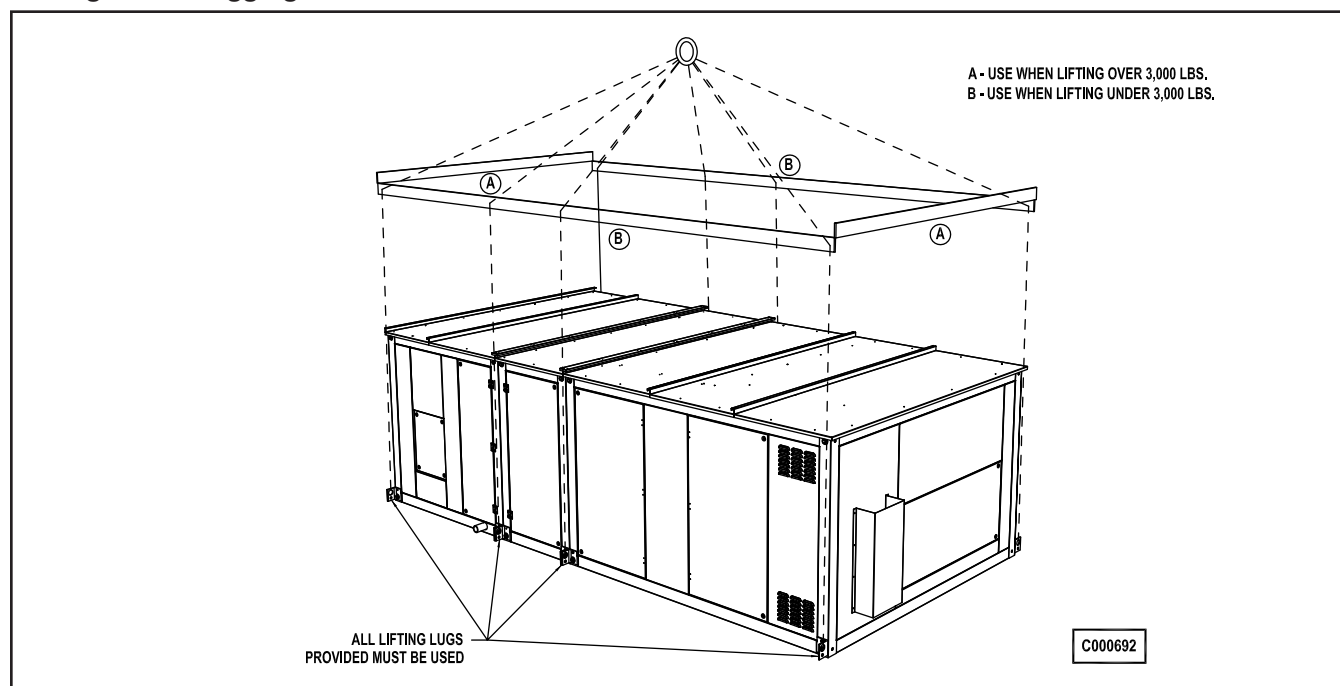

B. Locating The Unit

Prior to locating the unit, authorities having jurisdiction should be consulted before installations are made. Approval permits should be checked against the unit received.

For indoor application, combustion air shall be provided at a rate of at least 10 CFM, or 1 square inch of free opening, per 1000 BTU per hour of rated input. If a separate mechanical means provides this air, an interlock with the combustion blower shall be provided.

The rated output of gas burning appliances decreases with higher altitudes. Above 2,000 feet, the furnace shall be de-rated 4% for each additional 1,000 feet of altitude. Factory testing rating plate information is recorded on sea level conditions. High altitude ratings may be obtained by a change in manifold pressure. Appliances must be suitably marked to indicate their altitude adjusted input rating.

Under no circumstances should this equipment be installed in a negatively pressurized space. Consult jurisdictional authority for proper ventilation requirements.

Combustion air containing or recirculation of room air may be hazardous in the presence of:

- Flammable solids, liquids and gases.
- Explosive materials (i.e., grain, dust, coal dust, gunpowder, etc.)
- Substances, which may become toxic when, exposed to heat (i.e., refrigerant, aerosols, etc.).

Locate the unit exactly level. Special attention should be given to the duct, electrical, and fuel connection points. Install ductwork with adequate flexible connection to isolate vibration from the ductwork.

All ductwork should have taped or caulked seams. Ductwork should be properly sized so as not to inhibit airflow. This information should be crossed-checked with the position of support beams and stand pipes to insure that clearance dimensions coincide with those of the unit. Make a visual inspection to insure no damage has occurred to the unit during installation.

NOTE: Return air units must be ducted.

The minimum clearance to combustable material must be maintained as listed in Table 1.

Table 1
Minimum clearance to combustable material,
also consult local codes and regulations.

Clearances to Combustible Material	
Horizontal Units	
Front*	48 Inches
Rear	18 Inches
Right	18 Inches
Left	18 Inches
Top	18 Inches
Floor	6 Inches

* Consider control side as front of unit.

In addition to the combustable clearances listed above, access for service should be allowed around the unit. The recommended minimum access is 36" on front and rear sides for service access. Optimum clearance for coil removal for units with cooling coil section would be equivalent to cabinet width.

Field Assembly Drawing

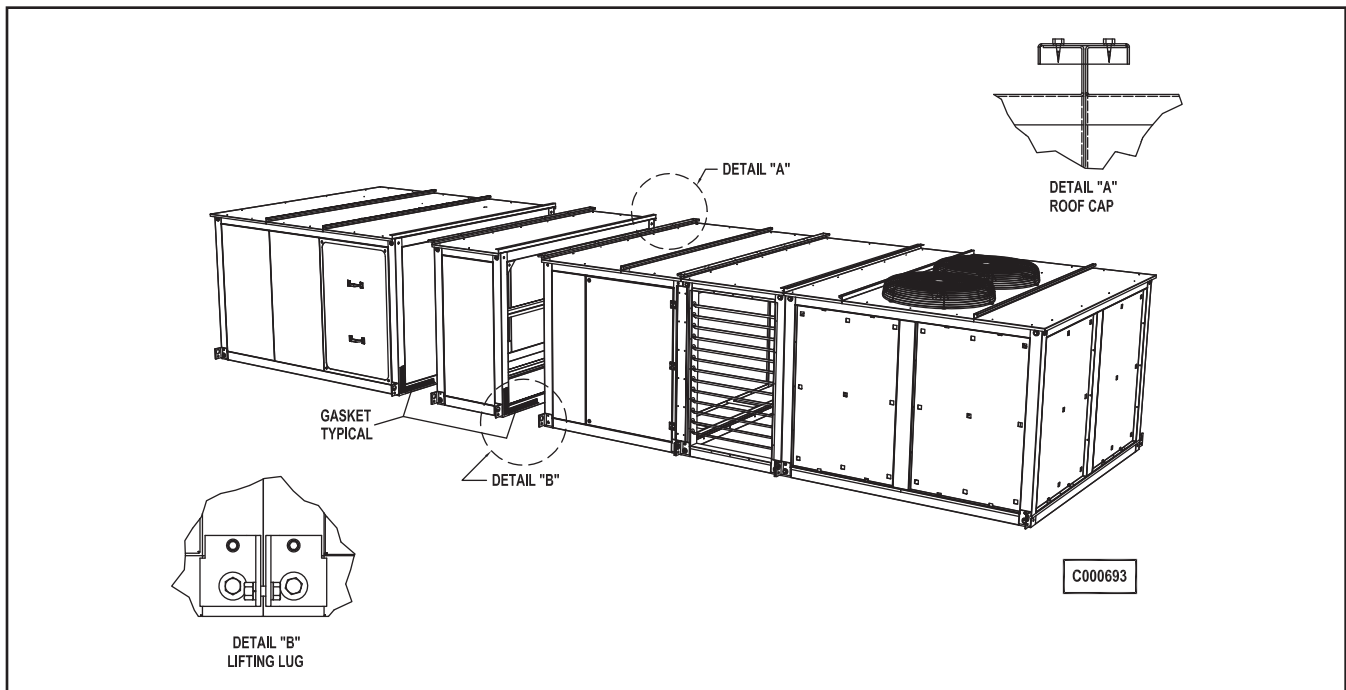

**DIRECTIONS FOR FIELD ASSEMBLING
AND WEATHERPROOFING SECTIONS**

1. Apply tacky tape gasket to the end of the first section (blower, discharge, heater, etc.). (See Fig. 1.)

NOTE: One roof cap is attached to a standing seam on each section for shipping purposes only. It will be necessary to remove this PRIOR TO SLIDING SECTIONS TOGETHER. Failure to do so may damage seams, preventing proper seal.

2. Slide adjoining section against the tacky taped first section. If bolt holes are provided, bolt the sections together tightly. If bolt holes are not provided, use furniture clamps to pull sections TIGHTLY together. Sections, whether bolted or not, will be held together and sealed by the standing seams and hugger strips (Fig. 2), which will be attached later.

3. Once the sections are connected, apply caulking or silicone sealant along the standing roof seam (Fig. 3) and side seams where the sections come together. (Fig.1) It is mandatory to seal the roof and side seams along the entire outside of the unit, and it is strongly suggested that the seams also be sealed along the inside of the unit, if possible.

4. Apply caulking material along the top of both sides of the standing roof seam (Fig.4). Place roof cap on top of the seam and secure it with two rows of TEK screws (one down each side). spaced approximately 8-10 inches apart down the entire length of the seam.

5. Apply two strips of tacky tape (one down each side) to the back side of each hugger strip (Fig. 2). Secure hugger strip with two rows of TEK screws (one down each side) spaced approximately 8-10 inches apart down the entire length of the seam.

6. After hugger strips are installed, caulk around the edges to complete the seal.

7. Repeat this process for each section as it is attached. The number of sections varies by application.

NOTE: HOOD REQUIRES ADDITIONAL, INSTALLER PROVIDED, SUPPORT.

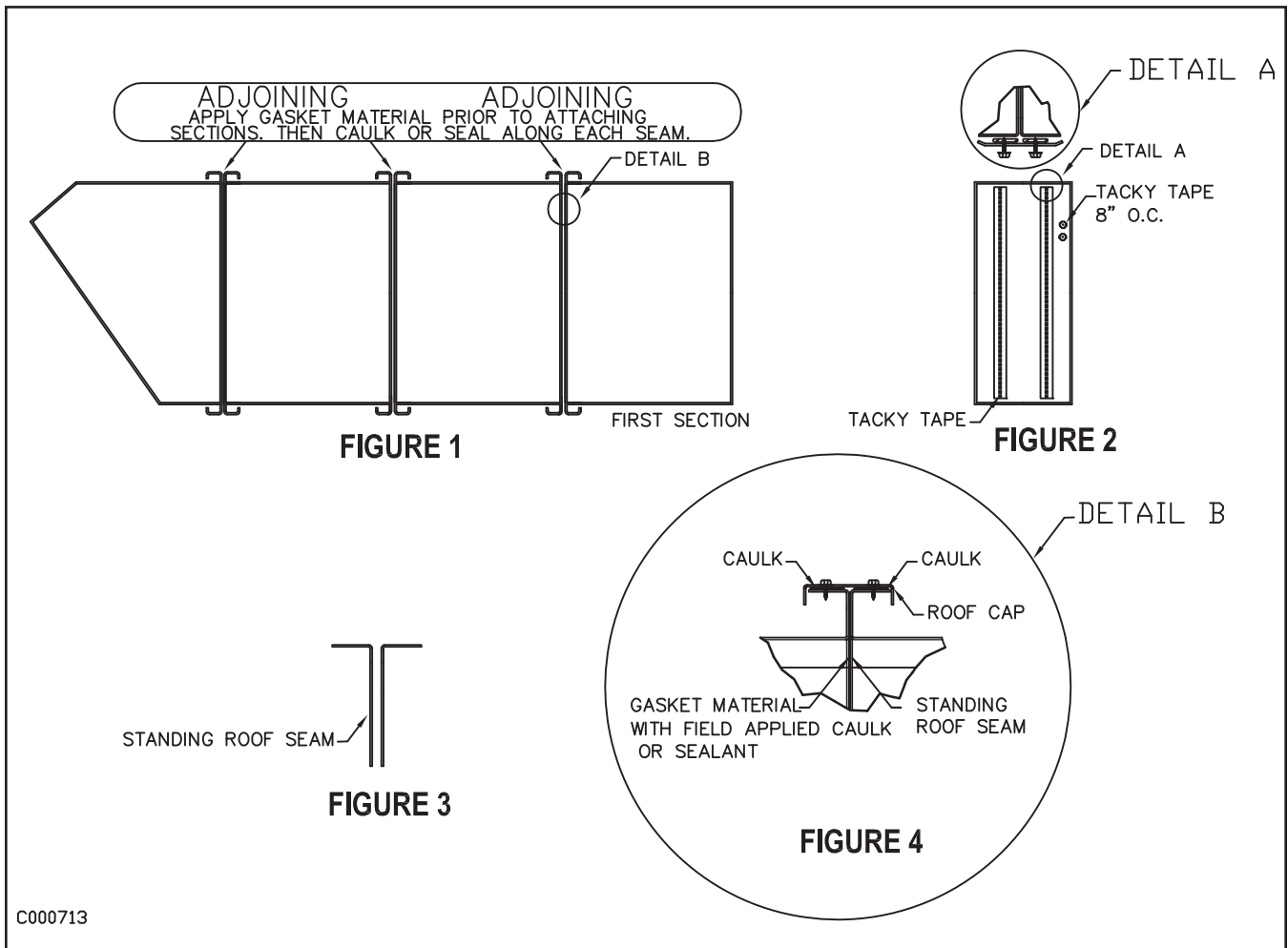

C. Location Of Accessories

Where applicable, standard or optional accessories will be placed inside the fan section of the unit for shipment and must be removed and installed by the mechanical or electrical contractor. Remotely located discharge or inlet dampers must be equipped with an end switch and interlocked to insure maximum design opening before starting and running circuits may be energized.

Adequate building relief must be provided, so as to not over-pressurize the building, when the system is operating at its rated capacity. This can be accomplished by taking into account, through standard engineering methods, the structure's designed infiltration rate, by providing properly sized relief openings, by interlocking a powered exhaust system, or by a combination of these methods.

D. Electrical Connections

Warning: Open all disconnect switches and secure in that position before wiring unit. Failure to do so may result in personal injury or death from electrical shock.

Warning: Controls must be protected from water. Do not allow water to drip on the ignition system.

NOTE: Before installing any wiring, check the unit rating plate for supply power voltage and amperage.

Since shipment of unit may require disassembly after factory check and test, reconnection of some electrical devices will be required in the field. Connect electrical wires (supplied in factory furnished conduit) to appropriate terminals. All leads are tagged to facilitate field connections. See wiring diagram provided with equipment. Complete all wiring to any optional accessories as shown on unit bill of material and electrical wiring diagram as required before applying voltage to the unit.

Entry location for all field-installed and control wiring is through the control panel.

If optional disconnect is not furnished with unit, the field provided disconnect must be of the proper size and voltage. Refer to unit rating plate for minimum circuit ampacity and voltage. The disconnect must be installed in accordance with Article 430 of the current edition of ANSI/NFPA No. 70 National Electrical Code.

Check the supply voltage before energizing the unit. The maximum voltage variation should not exceed $\pm 10\%$. Phase voltage unbalance must not exceed 2%.

NOTE: Should any original wire supplied with the heater have to be replaced, it must be replaced with wiring material having a temperature rating of at least 105° C.

REMARQUE: Dans le cas où un quelconque des câbles livrés avec l'unité devait être remplacé, il doit être remplacé avec des câbles prévus pour résister à une chaleur d'au moins 105° C.

E. Venting

All venting installations must conform to Part 7, Venting of Equipment in the current version of the National Fuel Gas Code ANSI Z223.1, or applicable provisions of local building codes.

All indoor units must be vented. Each heater must have an individual vent pipe and vent terminal. The heater used in this system is a Category III appliance and all portions of the venting system must be designed and installed so as to prevent leakage of flue or vent gases into a building.

Recommended vent pipe is 14 gauge Series 400 Stainless Steel. The customer must provide a rain cap or weatherproof cap. DO NOT support the weight of the stack and rain cap on the vent connection at the unit. Insulate single wall vent pipe exposed to cold air or running through unheated areas. Use as few elbows as possible and tape flue pipe joints with fireproof paper or approved material. All vents must be able to maintain the pressure stated on the rating plate in high fire.

Warning: CARBON MONOXIDE! Your venting system must not be blocked by any snow, snow drifts, or any foreign matter. Inspect your venting system to ensure adequate ventilation exists at all times! Failure to heed these warnings could result in carbon monoxide poisoning (symptoms include grogginess, lethargy, inappropriate tiredness, or flu-like symptoms).

The venting system shall terminate at least four feet below, four feet horizontally from, or one foot above any door, window, or gravity air inlet into any building. The Canadian B149.1, Natural Gas Installation Code specifies a six foot (1.83m) horizontal vent terminal clearance to gas and electric meters and relief devices.

Through the wall vents for these heaters shall not terminate over public walkways or over an area where condensate or vapor could create a nuisance or hazard or could be detrimental to the operation of regulators, relief valves, or other equipment.

The vent pipe diameter must be as shown in following chart. The stack diameter should be increased one size if the vent pipe is over fifty (50) feet in equivalent length.

Minimum Stack Diameter	
200 MBH Input (160 MBH Output)	4"
400 MBH Input (320 MBH Output)	6"
600 MBH Input (480 MBH Output)	7"

The vent pipe should be fitted with a drip leg with a clean out and a drain plug in the bottom. The vent pipe shall be constructed so that any water that collects in the stack will remain in the stack drip leg and not drain back into the heater collection box. Be sure drip leg is made so water will not fall on heater controls when drain plug is removed.

Pitch horizontal pipes upward 1/4 inch per foot toward outlet for condensate drainage. Support horizontal runs as required to prevent sagging.

Vents should terminate that will not cause a down draft to occur. This could affect the over-fire draft pressure in the heat exchanger. Do not install dampers or other restrictive devices in the flue vent pipe.

The stack should not be installed in such a manner that access to the components is obstructed. Guy wires may be required to brace the stack above rooflines.

Outdoor units are supplied with an integral vent pipe and vent terminal and no additional material is required. Provide a minimum of 36" clearance from combustible materials to the vent terminal.

F. Field Piping

Gas Piping

All gas piping must be in accordance with the requirements outlined in the National Fuel Gas Code – ANSI Z223.1. It is required that a ground union be installed adjacent to the manifold for easy servicing. A drip leg and/or filter should be provided upstream of the unit's inlet gas connection. An additional shut-off must be located external of the unit's enclosure where required by local code. The location of this valve must comply with all local codes. A 1/8 inch N.P.T. plugged tapping, accessible for test gauge connection, must be installed immediately upstream of the gas supply connection to the unit.

WARNING: To avoid equipment damage or possible personal injury, do not connect gas piping to this unit until a supply line pressure/leak test has been completed. Connecting the unit before completing the pressure/leak test may damage the unit gas valve and result in a fire hazard.

DANGER: Never use an open flame to detect gas leaks. Explosive conditions may exist which would result in personal injury or death.

The gas line should be supported so that no strain is placed on the unit. Pipe compounds, which are not soluble to liquid petroleum gases, should not be used on threaded joints.

Refer to the heater's rating plate for determining the minimum gas supply pressure for obtaining the maximum gas capacity for which this heater is specified.

Refer to the heater's rating plate for determining the maximum supply pressure to the heater.

The appliance and its individual shutoff valve must be disconnected from the gas supply piping system during any pressure testing of that system at test pressures in excess of 1/2 PSIG.

The appliance must be isolated from the gas supply piping system by closing it's individual manual shutoff valve during any pressure testing of the gas supply piping system at test pressure equal to or less than 1/2 PSIG.

Correctly sized piping must be run to the unit.

Please note that gas line pressure must be as shown on specification plate when unit is operating at full input. The high-pressure regulator and relief valve should be, if possible, mounted at least 5 to 10 feet upstream from the appliance regulator on the unit (if applicable).

Building Pressure Transducer Piping (PT-13)

Pipe the high side to location inside the building that will not be affected by air movement. Pipe the low side to the atmosphere, positioned so it will not be affected by the wind and not exposed to the elements. Be sure that all tubing is clean and clear of any debris before installing tubes on the transducer.

G. Field Wiring and Remote Control Installation

1. Connect the power lines to the line side of the power distribution block or optional main disconnect switch.
2. Field wiring is indicated on the wiring diagram typically as dashed lines. Where field wiring to the control circuit is required, take care to size the wires for a maximum 10% voltage drop. The VA rating of the transformer should be the maximum load.
3. Mount and wire remote control panel, thermostats, temperature sensors, and any other field installed controls as indicated on the unit control wiring diagram.

4. Connect all wiring to the appropriate field wiring terminal and any shielded or twisted wires as indicated on the unit control wiring diagram.
5. Field wiring shall have a temperature rating of at least 105° C. The minimum size of the supply cable circuit shall be sufficient for a maximum ampacity of the heater.

L'installation électrique d'utilisateur aura une température qui évalue d'au moins 105° C. La minimum de source du circuit de câblage sera suffisante pour le ampacity maximum de l'appareil de chauffage.

H. Locating Temperature Controls

The room or outdoor thermostats should be mounted where they will not be subjected to direct impact of the heated air or radiant heat from the sun. It is also recommended that the thermostats, especially those with mercury bulb contacts, be mounted on a vibration free surface. The sides of building columns, away from the heater or interior walls, are usually the location best suited for mounting thermostats.

Controls with outdoor bulbs require that the outdoor bulb be shielded from direct radiation from the sun. Unit mounted sensors are factory located and mounted.

I. Drains and Traps

Heat Exchanger – Furnaces are supplied with condensation removal pipe connections. Condensate from the heat exchanger is acidic and may contain chemical compounds requiring special drainage. The drain must be installed in accordance with all plumbing codes. The condensate is to be drained via PVC or steel pipe with an indirect connection to the plumbing wastes. Where a condensate neutralizer is used, an overflow shall be provided such that condensate will be directed to the drain in the event that the neutralizer becomes plugged. Indoor units typically require a condensate trap to be installed to prevent combustion gasses from entering the space. Outdoor units may require installing a heat trace or special attention to drains to prevent freezing and logging of the drain line.

Since the condensate is drained by gravity, avoid long runs of drain piping. If a long run of trapping cannot be avoided or the piping has water flow restrictions such as several elbows, add extra height to provide enough hydrostatic head to overcome the frictional losses. Always slope piping down a minimum of 1/8" per foot in the direction of the flow.

Cooling Coil – The cooling coil section is located in the unit so that supply air is drawn through the cooling coil(s). This results in the condensate being induced to the area of low static pressure. Unless some means of pressure equalization is provided in the condensate drain, the air rushing through the drain will cause the condensate to accumulate in the drain pan. As the unit continues to operate, the accumulated water will be picked up by the in-rushing air and carried with the air over the side of the drain pan causing possible water leaks into the supply duct and/or through the bottom of the unit causing water damage in the building. A trap should be installed to prevent this condensate water buildup. **See drawing below.** On initial startup, it may be necessary to fill the trap manually or, after unit has operated sufficiently for a small amount of condensate to collect in the drain pan, turn off the unit and the trap will automatically fill.

During the winter months when the cooling system is turned off and the unit is exposed to freezing conditions, an antifreeze solution should be poured into the condensate pan trap to prevent freezing and possible damage. The condensate drain trap may also be drained and capped, but be sure to remove the cap when starting the cooling for the next season.

Condensate Drain Drawing

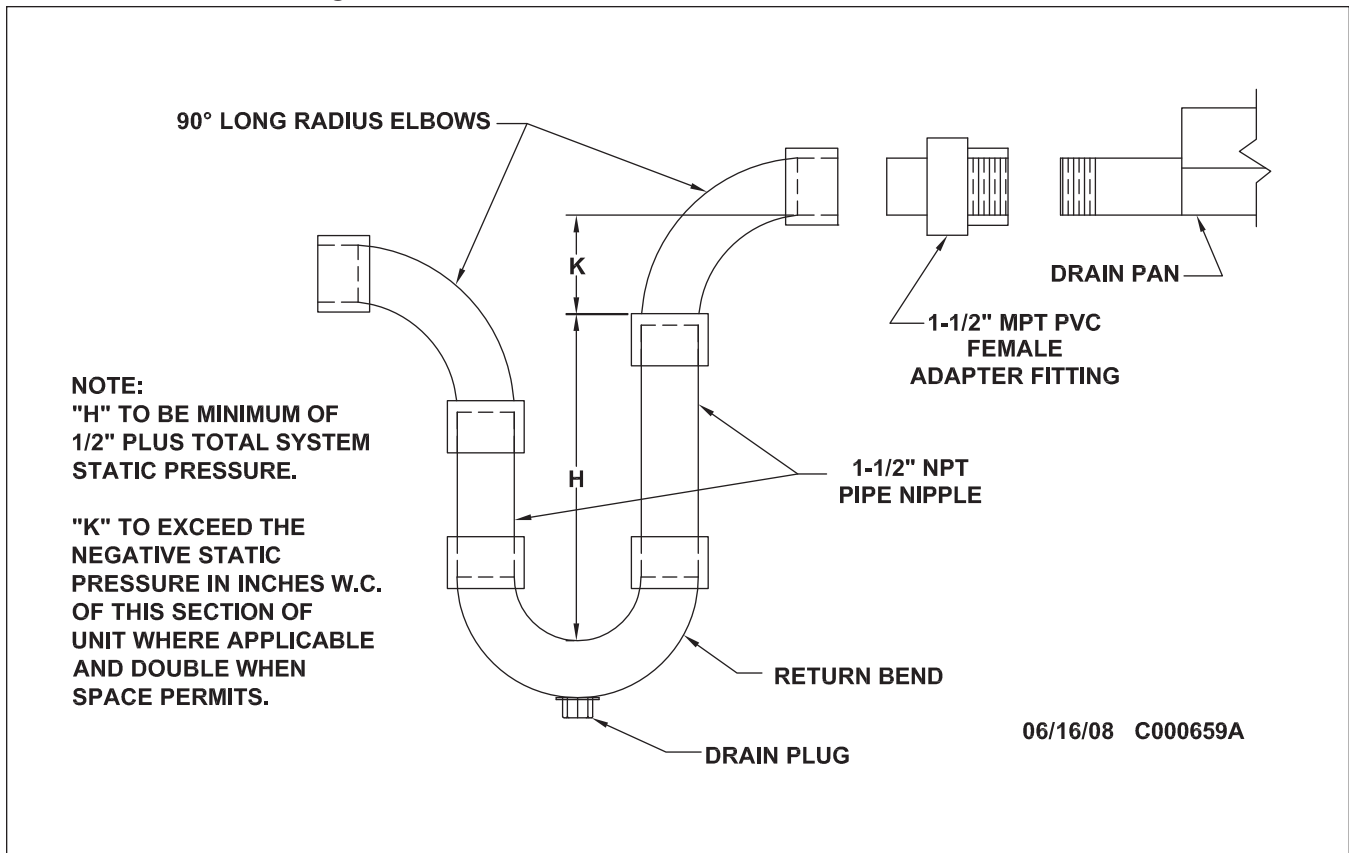

SECTION IV – PRE START-UP

Do not attempt start-up without completely reading and understanding this manual, along with the Digital Control System user manual.

A. Pre-Start-Up

The owner's representative or equipment operator should be present during start-up to receive instructions on care and adjustment of the equipment.

All equipment has been factory tested, adjusted, metered and inspected to meet conditions set at the time order was placed. Only minimal adjustments should be required. All information in this service manual is typical. All products are semi-custom and changes may occur.

CAUTION: Line side of disconnect may be energized. Follow proper "lockout/tagout" procedures.

NOTE: All servicing and adjustments of this piece of equipment should be preformed by a qualified service engineer.

Perform a visual inspection, internally and externally, of the unit to make sure no damage has occurred, and everything is secure. This inspection is very important and should be completed with greatest care given to detail. A good pre-start inspection will insure against possible unit damage on start-up and will save valuable analysis time.

1. Check that the physical condition of the unit exterior is acceptable.
2. Check that any insulation inside of unit is properly secured.
3. Remove all shipping blocks, brackets and bolts from supply fan base with optional isolation base.
4. Check all wiring for loose connections and tighten if necessary.
5. Inspect all fan and motor bearings and lubricate if necessary.

CAUTION: DO NOT RUPTURE GREASE SEALS.

6. Inspect pulleys and belts for tightness, tension and alignment. **Do not overtighten belts.**
7. Check set screws on all bearings, pulleys, fans and couplings for tightness.

8. Check voltage supplied to disconnect switch; the maximum voltage variation should not exceed $\pm 10\%$. Phase voltage unbalance must not exceed 2%.
9. Check the thermostat(s) for normal operation.
10. Check that system duct work is installed and free from obstructions.
11. Check that fans turn freely in housing.
12. Check that the area around the unit is clear of flammable vapors or containers of flammable liquids.
13. Check that all piping connections, particularly unions, are tight. Check all gas piping for leaks using a soap bubble solution. The most common types of problems found relative to the gas train itself is foreign material within the gas piping. This will interfere with the proper operation of the gas train components and burner. Purge all air from gas lines per gas codes.
14. Check that all accessories requiring field wiring have been properly installed.
15. Check that burner is securely mounted.
16. Check that filters, filter stops, accessories and ship loose items are installed correctly.
17. Check that vent lines (if applicable) are run to atmosphere on gas regulators and pressure switches for indoor units. Vent lines should terminate outside the building, with a turndown elbow and bug screen. Note that some units will use vent limiters and vent lines are not required. If vent lines are even partially plugged, this will interfere with proper venting of pressure control devices.
18. Check that all manual gas shut-off valves are closed.
19. When failure or malfunction of this unit creates a hazard to other fuel burning equipment, (e.g. when the unit provides make-up air to a boiler room), the unit is to be interlocked to open inlet air dampers or other such devices.
20. Motor overload relay setting should match the motor's nameplate full load amperage.
21. Check that dampers and linkages are free to move, and that linkages are tight.
22. Check to make sure all manual reset safety devices have been reset, and limits are in their normal operating position.
23. Check to make sure flue stack is installed properly and free from obstruction.
24. Do not attempt to start the burner when furnace is full of vapor or combustion chamber is very hot.

Suggested Tools and Instruments

Volt/Ohm Meter
Tachometer
Stack and Temperature Thermometer
Gas Pressure Gauge (0-35 lbs)
Ammeter
Manometer (0-10" W.C.)
Flue Gas Test Equipment
Draft Gauge
Standard Hand Tools
D.C. Voltmeter
Microammeter
BACview 6

Suggested Control Settings

FL-02 High Limit (Horz Discharge)200°F
FL-02 High Limit (Down Discharge).....165°F
FL-04 Auxiliary High Limit (Horz Discharge).....210°F
FL-04 Auxiliary High Limit (Down Discharge) .. 175°F
KP-01 Keypad/Display Module
..... Customer Discretion
MP-05 Damper Control Potentiometer
..... Customer Discretion
MP-15 Unit Enable Potentiometer
..... Customer Discretion
PS-04 Low Gas Pressure Switch 1.0" W.C.
PS-07 High Gas Pressure Switch
.....125% above burner firing rate
PS-12 Clogged Filter Switch
..... Adjust to field condition
PT-13 Building Pressure Transducer
..... Adjust to field condition
RE-21 Time Clock Customer Discretion
TC-09 Night Setback Thermostat
..... Customer Discretion

See Digital Control System User's Manual for DDC Controller default settings.

BEFORE ATTEMPTING TO START THE HEATER, READ THE TYPICAL SEQUENCE OF OPERATION AS SHOWN BELOW:

Typical Sequence of Operations Note:

This sequence is written for only the burner safety and operating portion of the heater. Other control systems for dampers, mixing boxes, and temperature controls are included in the unit typical sequence of operation and/or wiring diagram:

1. With main supply air blower on, and (DO-2) on (UC-01) Unit Control Module is energized, and all switches and operating controls in their normal position, the burner motor will run and "pre-purge" the combustion chamber. Pre-purge timing is not adjustable and is approximately 30 seconds.
2. With pre-purge timing complete, the pilot and/or gas valve along with the spark source are energized. If the pilot and/or burner does not light off or sense a flame before the end of the 15 second trial for ignition time, the control will shut off the spark and pilot and/or gas valve (100% shutoff). Remove and restore the power source to reset the control.
3. With the pilot and/or burner flame established, and when a sufficient flame current is sensed, the spark source is de-energized and the pilot and/or gas valve remains on.
4. The system is now in the run mode with the presence of the flame being continuously monitored by the flame rectification circuit. If the flame goes out, the control senses the loss of signal and de-energizes the pilot and/or gas valve. Flow of gas to the burner stops as the valve closes.
5. Once heating setpoint is satisfied, the pilot and/or gas valve, and burner motor will be de-energized. Main supply air blower will continue to run.

SECTION V – UNIT START-UP FAN AND HEAT

Before attempting to start the heater read and understand the sequence of operations, electrical schematic, gas train, burner, ignition control and the Digital Control System user manual.

WARNING: During installation, testing, servicing and troubleshooting of this product, it may be necessary to work with live electrical components. Have a licensed electrician or other individual who has been properly trained in handling live electrical components to perform these tasks. Failure to follow all electrical safety precautions when exposed to live electrical components could result in death or serious injury.

Make sure all manual gas valves are closed.

Make sure all doors and service panels have been closed or replaced.

Turn main disconnect switch off. Check the incoming line voltage to match unit rating plate. If voltage is over $\pm 10\%$ of nameplate rating or phase voltage unbalance is over 2%, notify contractor or power company.

Fan is Enabled And Disabled By The Following:

MDT And MRT Standard:

Rotate the remote “**Temperature Setpoint**” knob (MP-15). Clockwise will **enable** the fan. Counterclockwise will **disable** the fan.

MRT-PRO With Smart Room Sensor:

To enable the fan and place the unit in the Occupied Mode press the “**Manual On**” button on the face of the (TS-02) MRT-PRO room sensor. Pressing the “**Warmer**” button will add 30-minute increments of time for as total of 9-hours of operating time. To disable the fan and place the unit in the Unoccupied Mode press and hold down the “**Manual On**” button. Alternately pressing the “**Manual On**” button will also decrease the amount of operating time until it reaches zero and turns the fan off.

MRT Expert or VDT Expert With A BACview (KP-01):

To enable the fan go to “**Unit Modes**” and enter [MANUAL], this mode will enable the fan.

To also **enable** the fan go to “**Unit Modes**” and enter [AUTO], this mode has four different functions that control the fan and unit operation. They are a Time Clock, Heating and Cooling Night Setbacks, and signal from an external source to an auxiliary digital input.

To **disable** the fan go to “**Unit Modes**” and enter [OFF].

NOTE: A BACview or PC is required to change Unit Modes. For a more detailed control sequence see the Digital Control System user manual.

Turn main disconnect switch on and Enable fan. When (DO-1) fan relay is energized on (UC-01) the damper opens (if applicable), after end switch has proven damper is open, the blower will start (see operating modes in Digital Control System user manual.

Disable the fan. Check supply blower for proper rotation.

NOTE: To change rotation of the blower, simply interchange any two (2) of the leads of the motor starter for three (3) phase motors. On single-phase motors refer to motor nameplate.

Enable the fan. Check for proper blower rpm. Check that all motor amp draws do not exceed rating plate ratings and overloads are set to motor rating plate amps.

Check all dampers for proper operation, linkage does not bind, see “Sequence of Operation” and “Digital Control System user manual for damper control modes.

Disable the fan.

NOTE: When setting up the burner for the first time or if the appliance has been shut down for an extended period of time, these same start up procedures should be followed.

NOTE: Before attempting to light the pilot and main burner you need to review Circuit Analysis, Sequence and Burner Setup in Section XI for proper Manifold and Valve Adjustments. A BACview 6 or PC will be required to change setpoints.

Open first manual gas valve and check the gas supply pressure by replacing the plug fitting on the gas valve or line with a pressure gauge with appropriate range. Check that pressure reading is within the specified range on the rating plate.

NOTE: To adjust gas pressure on supply lines where a regulator has been installed (to reduce the inlet pressure to rating plate maximum pressure), remove dust cap of main gas regulator and turn adjusting screw clockwise to increase pressure or counterclockwise to decrease pressure.

Heat Is Enabled By The Following

MDT And MRT Standard:

To **enable** the heat rotate the “**Temperature Setpoint**” knob (**MP-15**) clockwise to the desired setpoint above the actual air temperature. The allowable temperature range is 55°F to 90°F.

MRT-PRO With Smart Room Sensor:

To **enable** the heat press the “**Warmer**” or “**Cooler**” button on the face of the remote (**TS-02**) MRT-PRO room sensor to the desired room setpoint. Each push of the button changes the temperature setpoint by 1°F. The setpoint can be changed a maximum of $\pm 10^\circ\text{F}$ from the default of 65°F. **Changing the heating setpoint also changes the cooling setpoint.**

MRT or VDT Expert With A (KP-01) BACview:

To **enable** the heat for MRT Expert scroll thru the “**SETPOINTS**” menu in the BACview and enter the desired room **Heating Occupied and Unoccupied Setpoints**. For VDT Expert enter the desired **Heating Discharge Air Setpoints**.

Energy Savings Modes:

There are 3-Energy Savings Modes that could disable the burner.

NOTE: A BACview or PC is required to change Setpoints. For a more detailed control sequence see the Digital Control System user manual.

CAUTION: Do not attempt to start the burner when furnace is full of vapor or combustion chamber is very hot.

Connect a DC microammeter between the Sense terminal and flame rod sensing wire on the flame safeguard relay (RE-02). A minimum of 1.2 microamps is required. See Troubleshooting Guide for Honeywell ignition control.

Connect the test instruments, meters, and thermometers on the heater and controls to measure and record the appropriate data.

SAFETY CHECKOUT

With power supplied to the ignition control (RE-02), and all safety devices are satisfied, the burner motor (MT-08) will run in pre-purge mode for 30 seconds. The pilot valve (VG-01), if applicable, or main gas valve (VG-02) is energized and a 15 second trial for ignition begins. If the flame-sensing probe fails to prove the pilot or main flame, it de-energizes the spark igniter and the control will lockout on flame failure (10 – 30 seconds). This safety step is performed to establish the flame sensing, and test any of the safety circuits before main flame light off.

Open pilot (if applicable) and first main gas shut-off valves **slowly**. Reset high-low gas pressure switches (if applicable). Check pilot and main gas lines for leaks using soap solution.

CAUTION: You will have approximately three (3) minutes before the unit shuts down on Freezestat (Low Discharge Temperature), if you have disconnected plug wires TS-01 and TS-03 referred to in Section XI.

Enable the fan and burner, adjust the setpoint to the highest setting to energize the heating relay (DO-02) on (UC-01).

NOTE: 3 OR 4 TRIALS MAY BE NEEDED TO PURGE AIR FROM GAS LINE.

Setting The Pilot Flame (if applicable)

NOTE: Pilot regulator (if applicable) adjustment may be needed to obtain the required microamp reading.

When the pilot is adjusted, shut the burner off by disabling heat.

Setting Main Flame

Install one manometer at test port on the elbow of the burner manifold for setting high fire manifold pressure, and one on the heat exchanger test port to insure proper overfire draft in high fire.

Slowly open all manual gas shut-off valves.

Enable the heat. After “pilot proven” (if applicable), main gas valve opens and burner lights. If the burner does not light within a few seconds after prepurge, shut the burner off and repeat the previous steps.

Burner will hold in low fire for approximately 10 seconds before modulating up. Adjust high fire pressure reading (from manometer) to match Normal Manifold Pressure firing rate shown on unit rating plate.

Refer to Valve Adjustment instructions in Section XI for setting high gas manifold pressure setting.

Check microamp reading with burner cycling through full firing range.

Cycle pilot and burner several times to insure smooth light off.

There should be a continuous spark for fifteen (15) seconds with pilot/gas supply turned off.

Check pilot and main gas lines for leaks.

Main flame is now set. See “Final Checks and Adjustments” on following page.

FINAL CHECKS AND ADJUSTMENTS – HEATING

With the gas input pressure established, the flue gas analysis can now be performed. This is done at the stack after unit is up to temperature.

The following readings should be taken but not limited to:

CO ₂ %	Net Stack Temperature
O ₂ %	Combustion Efficiency
CO%	

Check the combustion setting. The furnace has been test fired in the factory for firing rate and combustion. Field conditions may require adjustments to be made. These checks should be done by a qualified service man.

- a) When the main flame is established and the burner motor (MT-08) running at full speed, check the gas manifold pressure at the test point nearest the burner, downstream of the fully open modulating gas valve motor (MT-11). Check the nameplate for the correct pressure and adjust the appliance regulator if necessary.
- b) **Ensure proper overfire draft in high fire at test port in heat exchanger is set per rating plate.**
- c) Check the CO and O₂ reading at maximum input as shown on the rating plate. O₂ readings typically range from 4-6%. CO readings should not exceed 400 PPM at any time. Adjust the VG-02 gas regulator with the modulating gas valve motor fully open making fine adjustments before measuring again.
- d) Cycle burner several times to ensure smooth light off and proper operation. Visually observe the flame pattern. There must be no flame impingement or hot spots on the combustion chamber that could cause scaling.
- e) Check all gas piping again for leaks using a soap bubble solution.
- f) When the unit installation is complete, recheck the voltage and amp draw of each motor.
- g) Insure all safety controls are operative, i.e., ignition control, high limit, gas pressure switches, etc.
- h) Reset all operating controls back to proper setpoints for normal running conditions and make sure the burner modulates. See the Digital Control user manual.

The following list covers general combustion problems and some of the possible cures. Conditions may vary in the field. Refer to combustion chart for efficiency.

CAUTION: Check local codes for maximum allowable percentages and amounts of emissions.

Low Carbon Dioxide (CO₂)

- Fuel input too low
- Excess burner air
- Wrong draft setting

Detectable Carbon Monoxide (CO)

- Fuel input too high
- Not enough burner air
- Restricted draft
- Flame impingement

Excessive Stack Temperature

- Draft setting too high
- Incorrect burner air
- Fuel input too high

Low Oxygen (O₂)

- Oxygen reading must always be a positive percentage

Check all dampers, linkages, and locking quadrants to make sure they are secure and operating correctly.

SAFETY AND CONTROLS CHECKOUT

Ignition Control – Close manual gas valve before burner. Operate unit in heat mode. After pilot flame has been established, close manual pilot gas valve (if applicable). The ignition control must trip out within 10-30 seconds.

Gas Pressure Switches - The low gas pressure switch will trip out and must be reset before resuming operation when the inlet gas shut off valve is turned off, or inlet gas pressure is lower than the trip point. The high gas pressure switch can be checked by reducing the setting of its trip point lower than the burner operating pressure. The switch should trip out and shut off the burner. Return the adjustment to its original setting and reset to resume operation.

Temperature Controls – The temperature controls are checked by adjusting control to a higher temperature to allow burner to cycle on. Adjust control to a lower temperature to allow burner to cycle off. Return the adjustment to its original setting.

Limit Controls - The limit controls are checked by adjusting control to a lower temperature setting while the unit is operating on high fire and observe cut-off. Return the adjustment to its original setting. Manual reset may be required on some controls.

Make sure all the safeties and controls are working properly.

SECTION V continued – UNIT START-UP COOLING

Before attempting to start the cooling read and understand the sequence of operations and electrical schematic, and the Digital Control System user manual.

WARNING: During installation, testing, servicing and troubleshooting of this product, it may be necessary to work with live electrical components. Have a qualified licensed electrician or other individual who has been properly trained in handling live electrical components to perform these tasks. Failure to follow all electrical safety precautions when exposed to live electrical components could result in death or serious injury.

Make sure all cooling valves are open.

Make sure all doors and service panels have been closed or replaced.

Prior to unit start-up, condensate trap should be filled with water and checked for leaks.

Turn main disconnect switch off. Check the incoming line voltage to match unit rating plate. If voltage is over $\pm 10\%$ of nameplate rating or phase voltage unbalance is over 2%, notify contractor or power company.

Cooling Is Enabled By The Following

MDT & MRT Standard:

To **enable** the cooling rotate the remote “**Temperature Setpoint**” knob (**MP-15**) clockwise to the desired setpoint below the actual air temperature. The allowable temperature range is 55°F to 90°F.

MRT-PRO With Smart Room Sensor:

To **enable** the cooling press the “**Warmer**” or “**Cooler**” button on the face of the remote (**TS-02**) **MRT-PRO** room sensor to the desired room setpoint. Each push of the button changes the temperature setpoint by 1°F. The setpoint can be changed a maximum of $\pm 10^\circ\text{F}$ from the default of 73°F. **Changing the cooling setpoint also changes the heating setpoint.**

MRT or VDT Expert With a (KP-01) BACview:

To **enable** the cooling for MRT Expert scroll thru the “**SETPOINTS**” menu in the BACview and enter the desired room **Cooling Occupied** and **Unoccupied Setpoints**. For VDT Expert enter the desired **Cooling Discharge Air Setpoints**.

Energy Savings Mode:

Energy Savings Mode 4-can disable the cooling.

NOTE: The cooling outputs are protected by an anti-cycle timer which has a 3 minute off / 3 minute on delay. A BACview or PC is required to change Setpoints. For a more detailed control sequence see the Digital Control System user manual.

Turn main disconnect switch on and Enable fan. When (DC-01) fan relay is energized on (UC-01) the damper opens (if applicable). After end switch has proven the damper is open, blower fan starts. See operating modes in Digital Control System user manual.

If trying to start or checkout cooling in a low ambient condition, you will need to install a jumper in place of the outdoor air sensor (TS-01) and the discharge air sensor (TS-03). This will drive the unit to call for full cooling and energizes cooling relays (DO-3 and DO-4) on (UC-01).

SECTION VI – UNIT SHUTDOWN

A. Extended Shutdown

1. Disable the heating and cooling circuits.
2. Close the Manual Firing Valve in the heater gas piping manifold.
3. If the furnace was firing at the time of shutdown allow the main supply blower to run for a sufficient period to cool off the heat exchanger. The furnace may have an automatic blower override that will perform this function automatically, running the blower until the air reaches a fan cut-off temperature.

4. Disable the fan.
5. Turn the unit main power disconnect to the “off” position.
6. Close all the manual gas shut-off valves.
7. If the unit is to remain idle for an extended period, the blower and motor shafts should be rotated by hand to spread the grease over the bearings.

B. Emergency Shutdown Only

1. Open the main electrical disconnect switch.
2. Close the main manual gas valve.

SECTION VII – TROUBLE SHOOTING

Check Safety Shutdown Performace (RE-02)

WARNING: Fire or explosion hazard. Can cause property damage, severe injury or death. Perform the safety shutdown test any time work is done on a gas system.

NOTE: Read steps 1 through 7 before starting, and compare to the safety shutdown or safety lockout tests recommended for the intermittent pilot (IP) ignition module. Where different, use the procedure recommended for the module.

1. Turn off gas supply at valve.
2. Set thermostat or controller above room temperature to call for heat.
3. Watch for ignition spark following prepurge. See ignition module specifications.
4. Time the length of the spark operation. See the ignition module specifications.
5. After the module locks out, open the manual gas cock and make sure no gas is flowing to the pilot or main burner.
6. Reset the ignition module (RE-02).
7. Operate system through one complete cycle to make sure all controls operate properly.

This equipment has been electrically and fire tested prior to shipment. However, during transit control setpoints can change, and wiring can come loose. Do not assume controls are defective until all associated setpoints and wiring are checked.

If you do not have the optional BACview 6 (KP-01) keypad display it will be difficult to troubleshoot any alarm that may occur on the unit. To reset most alarms on the I/O Zone 583 Controller (UC-01) without a BACview 6 keypad display, simply turn the power off and back on at the unit disconnect. If you have a BACview 6 keypad display the alarm can be reset remotely or at the I/O Zone 583 Controller.

The following is a simplified list of possible problems and typical causes and remedies. However, it does not cover all possibilities, and is intended as a guide only. **You might also need to reference the Digital Control System User Manual for additional troubleshooting and diagnostics.**

WARNING: Many of the steps listed on the following pages require electrical cabinet and blower access while the unit is powered. High voltage and moving parts are present, and these steps should be performed by qualified service personnel. If any of the controls requiring manual reset were at fault this is an indication of a problem with the system that should be investigated.

Refer to manufacturer’s IOM for additional troubleshooting information.

S8600B,C,H,M; S8610B,C,H,M; S8670D,E,J,K Intermittent Pilot Gas Ignition Control

INSTALLATION INSTRUCTIONS

APPLICATION

The 8600 family of ignition controls provide ignition sequence, flame monitoring and safety shutoff for intermittent pilot gas fired heating appliances. These controls provide flame sense and operating sequences suitable for the application.

Table 1 describes the main features of each available model.

Table 1. Intermittent Pilot Ignition Models.

Model	Igniter-Sensor Type	Valve Current Rating @ 24 Vac	Prepurge Timing	Trial for Pilot Ignition	Ignition Sequence Type	Ignition Sequence Description ^a
S8600B	Separate ^b	1.0 A Pilot and 1.0 A Main	None	15 or 90 seconds, as ordered	Lockout	Spark and pilot gas ON until lightoff or trial for ignition ends. If pilot fails to light, pilot gas and spark OFF (100% shutoff), and lockout. Cycle "Call for Heat" to restart ignition sequence.
S8600C	Separate	1.0 A Pilot and 1.0 A Main	None	15 or 90 seconds, as ordered	Continuous Retry	Spark and pilot gas ON until lightoff or trial for ignition ends. If pilot fails to light, pilot gas and spark OFF (100% shutoff). After 5 minute delay, a new trial for ignition is initiated. This sequence continues until lightoff or "Call for Heat" is removed.
S8600H	Combination ^c	1.0 A Pilot and 1.0 A Main	None	15 or 90 seconds, as ordered	Lockout	Spark and pilot gas ON until lightoff or trial for ignition ends. If pilot fails to light, pilot gas and spark OFF (100% shutoff), and lockout. Cycle "Call for Heat" to restart ignition sequence.
S8600M	Combination	1.0 A Pilot and 1.0 A Main	None	15 or 90 seconds, as ordered	Continuous Retry	Spark and pilot gas ON until lightoff or trial for ignition ends. If pilot fails to light, pilot gas and spark OFF (100% shutoff). After 5 minute delay, a new trial for ignition is initiated. This sequence continues until lightoff or "Call for Heat" is removed.
S8610B	Separate	1.0 A Pilot and 2.0 A Main	None	15 or 90 seconds, as ordered	Lockout	Spark and pilot gas ON until lightoff or trial for ignition ends. If pilot fails to light, pilot gas and spark OFF (100% shutoff), and lockout. Cycle "Call for Heat" to restart ignition sequence.
S8610C	Separate	1.0 A Pilot and 2.0 A Main	None	15 or 90 seconds, as ordered	Continuous Retry	Spark and pilot gas ON until lightoff or trial for ignition ends. If pilot fails to light, pilot gas and spark OFF (100% shutoff). After 5 minute delay, a new trial for ignition is initiated. This sequence continues until lightoff or "Call for Heat" is removed.
S8610H	Combination	1.0 A Pilot and 2.0 A Main	None	15 or 90 seconds, as ordered	Lockout	Spark and pilot gas ON until lightoff or trial for ignition ends. If pilot fails to light, pilot gas and spark OFF (100% shutoff), and lockout. Cycle "Call for Heat" to restart ignition sequence.



Automatic Ignition Systems
ANSI Z21.20



69-1954

Table 1. Intermittent Pilot Ignition Models. (Continued)

Model	Igniter-Sensor Type	Valve Current Rating @ 24 Vac	Prepurge Timing	Trial for Pilot Ignition	Ignition Sequence Type	Ignition Sequence Description ^a
S8610M	Separate	1.0 A Pilot and 2.0 A Main	None	15 or 90 seconds, as ordered	Continuous Retry	Spark and pilot gas ON until lightoff or trial for ignition ends. If pilot fails to light, pilot gas and spark OFF (100% shutoff). After 5 minute delay, a new trial for ignition is initiated. This sequence continues until lightoff or "Call for Heat" is removed.
S8670D	Combination	1.0 A Pilot and 2.0 A Main	30 seconds	15 or 90 seconds, as ordered	Lockout	After prepurge, spark and pilot gas ON until lightoff or trial for ignition ends. If pilot fails to light, pilot gas and spark OFF (100% shutoff), and lockout. Cycle "Call for Heat" to restart ignition sequence.
S8670E	Combination	1.0 A Pilot and 2.0 A Main	30 seconds	15 or 90 seconds, as ordered	Continuous Retry	After prepurge, spark and pilot gas ON until lightoff or trial for ignition ends. If pilot fails to light, pilot gas and spark OFF (100% shutoff). After 5 minute delay, a new trial for ignition is initiated. This sequence continues until lightoff or "Call for Heat" is removed.
S8670J	Separate	1.0 A Pilot and 2.0 A Main	30 seconds	15 or 90 seconds, as ordered	Lockout	After prepurge, spark and pilot gas ON until lightoff or trial for ignition ends. If pilot fails to light, pilot gas and spark OFF (100% shutoff), and lockout. Cycle "Call for Heat" to restart ignition sequence.
S8670K	Separate	1.0 A Pilot and 2.0 A Main	30 seconds	15 or 90 seconds, as ordered	Continuous Retry	After prepurge, spark and pilot gas ON until lightoff or trial for ignition ends. If pilot fails to light, pilot gas and spark OFF (100% shutoff). After 5 minute delay, a new trial for ignition is initiated. This sequence continues until lightoff or "Call for Heat" is removed.

^a If established flame is lost, all models restart ignition trial.

^b Separate: two rod; remote flame sensing.

^c Combination: one rod; local flame sensing.

All models provide:

- Natural or LP gas.
- Pilot burner ignition using a high voltage spark.
- Flame rectification circuit to monitor flame presence.
- Monitoring of 24 Vac, pilot, and main gas valve.
- Two LED indicators for flame presence/strength and system status/errors.
- EnviraCOM™ communication protocol for system diagnostics.
- Optional: Alarm Output dry contacts (Lockout models Only).

SPECIFICATIONS

Control Voltage: 24V (18-30 Vac) 50/60 Hz
Current Draw: 0.1 A plus valve load @ 24Vac
Trial for Ignition: 15 or 90 seconds (depends on model)
Prepurge: See Table 1.

Ignition Sequence: See Table 1.

Retry Delay: 5 minutes (C, M, E, and K models only)

Flame Failure Response Time: 2 seconds maximum

LEDs: Two LEDs provide the following:

- The Status LED (green) provides system status and error codes.
- The Flame LED (yellow) indicates flame presence and flame strength.

Gas Control: Honeywell models VR8204 and VR8304

Operating Temperature:

Minimum ambient temperature rating is -40°F (-40°C).

Maximum ambient rating for S8600 used with 1.0A main valve is 175°F (79°C).

Maximum ambient rating for S8610 and S8670 used with 2.0A main valve is 165°F (74°C).

Relative humidity: 0% to 95% noncondensing

PLANNING THE INSTALLATION

WARNING

Fire or Explosion Hazard.

Can cause severe injury, death or property damage.

1. Plan the installation as outlined below.
2. Plan for frequent maintenance as described in the Maintenance section.

Intermittent pilot systems are used on a wide variety of central heating equipment and on heating appliances such as commercial cookers, agricultural equipment, industrial heating equipment and pool heaters. Some of these applications may make heavy demands on the controls, either because of frequent cycling, or because of moisture, corrosive chemicals, dust or excessive heat in the environment. In these situations, special steps may be required to prevent nuisance shutdowns and premature control failure. These applications require special Honeywell review; contact your Honeywell Sales Representative for assistance.

Review the following conditions that can apply to your specific installation and take the precautionary steps suggested.

Frequent Cycling

These controls are designed for use on appliances that typically cycle three to four times an hour only during the heating season. In year-round applications with greater cycling rates, the control can wear out more quickly; perform a monthly checkout.

Water or Steam Cleaning

If the control gets wet, replace it. If the appliance is likely to be cleaned with water or steam, protect (cover) the controls and wiring from water or steam flow. Mount the controls high enough above the bottom of the cabinet so they do not get wet during normal cleaning procedures. Use a NEMA 4 enclosure for the ignition control.

High Humidity or Dripping Water

Dripping water can cause the control to fail. Never install an appliance where water can drip on the controls.

In addition, high ambient humidity can damage the control.

If the appliance is in a humid atmosphere, make sure air circulation around the controls is adequate to prevent condensation. Also, regularly check out the system. A NEMA 4 enclosure is recommended for the ignition module.

Corrosive Chemicals

Corrosive chemicals can attack the module and gas control, eventually causing a failure. If chemicals are used for routine cleaning, make sure they do not reach the controls. Where chemicals are suspended in air, as in some industrial or agricultural applications, use a NEMA 4 enclosure for the ignition module.

Dust or Grease Accumulation

Heavy accumulations of dust or grease can cause controls to malfunction. Where dust or grease can be a problem, provide covers for the module and the gas control to limit contamination. A NEMA 4 enclosure is recommended for the ignition module.

Heat

Excessively high temperatures can damage controls. Make sure the maximum ambient temperature at the control does not exceed the rating of the control. If the appliance operates at very high temperatures, use insulation, shielding, and air circulation, as necessary, to protect the controls. Proper insulation or shielding should be provided by the appliance manufacturer; verify proper air circulation is maintained when the appliance is installed.

INSTALLATION

When Installing This Product...

1. Read these instructions carefully. Failure to follow them could damage the product or cause a hazardous condition.
2. Check the ratings given in these instructions to make sure the control is suitable for your application.
3. Installer must be a trained, experienced service technician.
4. After installation is complete, check out operation as provided in these instructions.

WARNING

Fire or Explosion Hazard.

Can cause severe injury, death or property damage.

1. The module can malfunction if it gets wet, leading to accumulation of explosive gas.
 - Never install where water can flood, drip or condense on the module.
 - Never try to use a module that has been wet—replace it.
2. Liquefied petroleum (LP) gas is heavier than air and will not naturally vent upward.
 - Do not operate electric switches, lights, or appliances until you are sure the appliance area is free of gas.

WARNING

Electrical Shock Hazard.

Can cause severe injury, death or property damage.

Disconnect power supply before beginning wiring or making wiring connections to prevent electrical shock or equipment damage.

CAUTION

1. If a new gas control is to be installed, turn off the gas supply before starting installation. Conduct a Gas Leak Test according to the gas control manufacturer instructions after the gas control is installed.
2. Wiring errors can cause improper appliance operation and dangerous conditions such as bypassing safety features.

CAUTION

Equipment Damage Hazard.

Water can cause equipment damage or malfunction.

If the module must be mounted near water or moisture, provide suitable waterproof enclosure.

Maintenance Requirements in Severe Environments

Regular preventive maintenance is important in any application.

WARNING

Fire or Explosion Hazard.

May cause severe injury, death or property damage.

Do not attempt to take the module apart or to clean it. Improper reassembly and cleaning may cause unreliable operation.

Maintenance frequency must be determined individually for each application. Some considerations are:

- Cycling frequency. Appliances that may cycle more than 20,000 times annually should be checked monthly.
- Intermittent use. Appliances that are used seasonally should be checked before shutdown and again before the next use.

- Consequence of unexpected shutdown. Where the cost of an unexpected shutdown would be high, the system should be checked more often.
- Dusty, wet, or corrosive environment. Since these environments can cause the modules to deteriorate more rapidly, the system should be checked more often.

Any module should be replaced if it does not perform properly on checkout or troubleshooting. In addition, replace any module if it is wet or looks like it has ever been wet. Protective enclosures as outlined under "Planning the Installation" are recommended regardless of checkout frequency.

Location

The mounting location must provide:

- Good, clear access to the field wiring terminals.
- Operating ambient temperatures between -40°F and 175°F (-40°C and 79°C); (165°F [74°C] for S8610 and S8670 models).
- Relative humidity below 95% noncondensing.
- Protection from water, steam or corrosive chemicals that are used to clean the appliance.
- Protection from dripping water, such as from an overfilled humidifier or from condensation.
- Protection from dust or grease accumulation.

Mount the Ignition Module

Select a location close enough to the burner to allow a short (3 ft. [0.9 m] max.), direct cable route to the pilot burner. Ambient temperature at the module must be within the range listed under *Operating Temperature*, on page 2. The module must be protected from water, moisture, corrosive chemicals and excessive dust and grease.

Mount the module with the terminals down to protect them from dripping water and dust. As an alternative, it can also be mounted with the terminals on either side.

IMPORTANT

Do not mount with terminals facing up.

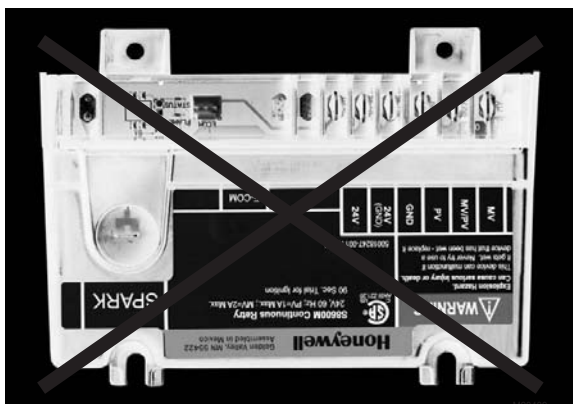

Fig. 1. Incorrect Mounting (Model S8600M shown).

Fasten securely with four No. 6-32 machine or No. 8 sheet metal screws.

Mount the System Controls

Mount any required controls, such as the gas control, spark igniter, flame sensor, thermostat, limit, and transformer according to manufacturer's instructions.

Wire the System

CAUTION

Equipment Damage Hazard.

Disconnect power supply before beginning wiring or making wiring connections to prevent electrical shock or equipment damage.

All wiring must comply with local codes and ordinances. See Fig. 2 and Table 4 for proper wiring connections.

IMPORTANT

1. As shown in the wiring diagrams, a common ground is required on:
 - a The pilot burner mounting bracket, and
 - b The GND(BURNER) terminal on the ignition module. Failure to use the GND(BURNER) terminal may result in intermittent loss of spark and/or loss of flame current sensitivity.
2. Make sure the transformer has adequate VA. The ignition module requires at least 0.1 A at 24 Vac. Add the current draws of all other devices in the control circuit, including the pilot and main valves in the gas control, and multiply by 24 to determine the total VA requirement of these components. Add this total to 2.4 VA (for the ignition module). The result is the minimum transformer VA rating. Use a Class II transformer if replacement is required.

CONNECT IGNITION CABLE

Use Honeywell ignition cable or construct an ignition cable that conforms to suitable national standards such as Underwriters Laboratories Inc. See Table 2 and Table 3.

Table 2. Honeywell Pre-assembled Ignition Cables (UL Style 3257).

CABLE PART NUMBER	LENGTH	MODULE END	PILOT BURNER
394800-30	30 inches	1/4 inch quick connect, insulated	Rajah connector receptacle, 90 degree rubber boot
394801-30	30 inches	1/4 inch quick connect, insulated	Rajah connector receptacle, straight rubber boot

Table 3. Recommended Ignition Cable for Field Assembly.

CABLE TYPE	VOLTAGE RATING (rms)	TEMPERATURE RATING
UL Style 3217	10,000	302°F (150°C)
UL Style 3257	10,000	484°F (250°C)

Cable must be no longer than 36 in. (0.9 m). To construct a cable, fit one end of ignition cable with 1/4 in. diameter Rajah connector receptacle and the other with a 1/4 in. female quick connect. Protect both ends with insulated boots.

NOTE: The cable must not run in continuous contact with a metal surface or spark voltage will be greatly reduced. Use ceramic or plastic standoff insulators as required.

To install:

- (1) Connect one end of the cable to the male quick connect SPARK terminal on the ignition module.
- (2) Connect the other end of the cable to the igniter or igniter-sensor stud on the pilot burner/igniter-sensor.

CONNECT IGNITION MODULE

NOTE: Refer to Fig. 2 and Table 4 for the location of each connection.

Connect remaining system components to the ignition module terminals as shown in the appropriate wiring diagram.

- Fig. 3 is a basic circuit for the H and M models used in heating systems with atmospheric burners.
- Fig. 4 shows the basic circuit for the B and C models with separate sensor and igniter in a heating system with atmospheric burners.
- Fig. 5—8 show typical circuits for power assisted combustion applications and two-stage gas control with power assisted combustion applications.

MAKE FLAME SENSE CONNECTION

For B, C, J, and K models:

These models have remote flame sensing (two rod). Connect the flame sensor wire from the Pilot burner/igniter to the SENSE connector on the ignition module.

For H, M, D, and E models:

These models have local flame sensing (single rod). The spark lead carries the flame signal.

CONNECT GAS CONTROL

Use 18-gauge solid or stranded wire. Use 1/4 in. female quick connects for module connections. Connect to gas control terminals as shown in wiring diagrams, using terminals appropriate to the gas control.

GROUND CONTROL SYSTEM

The igniter, flame sensor and ignition module must share a common ground with the pilot burner. Use thermoplastic insulated wire with a minimum rating of 221°F (105°C) for the ground wire; asbestos insulation is not acceptable. If necessary, use a shield to protect the wire from radiant heat generated by the burner. Connect the ground wire as follows:

1. Fit one end of the ground wire with a female 1/4 in. quick-connect terminal and connect it to the male quick-connect BRN GND terminal on the ignition module.
2. Strip the other end of the wire and fasten it under the pilot burner bracket mounting screw. If necessary, use a shield to protect the ground wire from radiant heat.
3. The pilot burner serves as the common grounding area. If there is not good metal-to-metal contact between the pilot burner and ground, run a lead from the pilot burner to ground.

NOTE: Earth ground is not required.

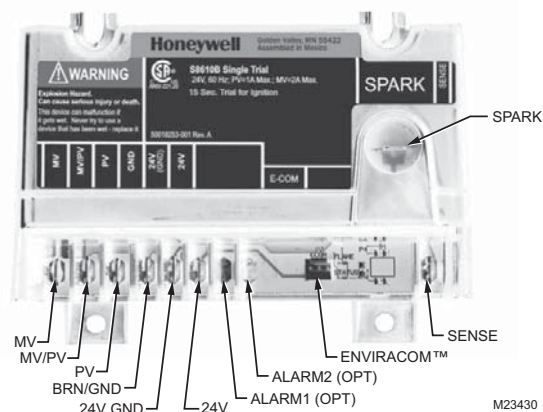

Fig. 2. Ignition Module wiring connection locations (Model S8610B shown).

Table 4. Wiring Connection Descriptions.

Connector Label	Size	Description
MV	1/4 inch	Main Valve connection
MV/PV	1/4 inch	Common terminal for gas valve
PV	1/4 inch	Pilot Valve connection
BRN GND	1/4 inch	Burner Ground
24V GND	1/4 inch	Return path to transformer
24V	1/4 inch	24 Vac (“Call for Heat”)
ALARM1	3/16 inch	Alarm connection (optional for B, H, D, and J models only)
ALARM2	3/16 inch	Alarm connection (optional for B, H, D, and J models only)
EnviraCOM™	3-pin	EnviraCOM™ communications connector
SENSE	3/16 inch	Flame Sensor (B, C, J, and K models Only)
SPARK	1/4 inch	High voltage sparking electrode

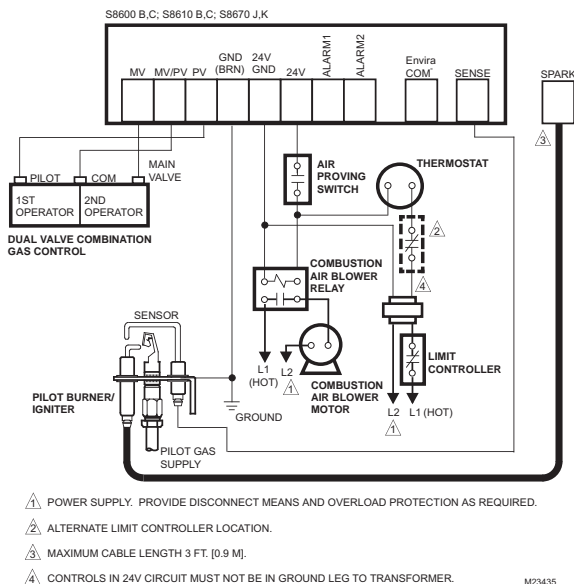

Fig. 7. S8600 B,C; S8610 B,C; S8670 J,K connections with remote flame sensing in a heating system with power-assisted combustion.

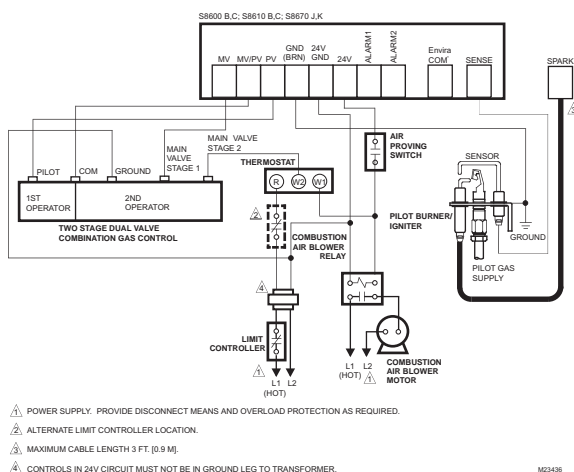

Fig. 8. S8600 B,C; S8610 B,C; S8670 J,K connections with remote flame sensing in a heating system with a two-stage gas control and power-assisted combustion.

CHECKOUT

Check out the gas control system:

- At initial installation of the appliance.
- As part of regular maintenance procedures. Maintenance intervals are determined by the application. See “Planning the Installation” on page 2 for more information.
- As the first step in troubleshooting.
- Any time work is done on the system.

WARNING

Fire or Explosion Hazard.
Failure to heed these warnings may cause fire or explosion with property damage, injury, or loss of life.

1. If you smell gas or suspect a gas leak, turn off gas at manual service valve and evacuate the building. Do not try to light any appliance, do not touch any electrical switch or telephone in the building until you are sure no spilled gas remains.
2. Gas leak test must be done as described in the steps below on initial installation and any time work is done involving the gas piping.

Step 1: Perform Visual Inspection.

- a. With power off, make sure all wiring connections are clean and tight.
- b. Turn on power to appliance and ignition module.
- c. Open manual shutoff valves in the gas line to the appliance.
- d. Perform Gas Leak Test ahead of gas control if piping has been disturbed.

GAS LEAK TEST:

Paint the gas control gasket edges and all pipe connections upstream of the gas control with a rich soap and water solution. Bubbles indicate gas leaks. Tighten the joints and screws or replace component to stop gas leak. Recheck with soap and water solution.

Step 2: Verify control system ground.

The igniter, flame sensor, and ignition module must share a common ground with the main burner. Use thermoplastic insulated wire with a minimum rating of 221°F (105° C) for the ground wire; asbestos insulation is not acceptable. If the temperature at the wire could exceed 221°F (105°C), use a shield to protect the wire from radiant heat generated by the burner. Connect the ground wire as follows:

- a. Fit one end of the ground wire with a female 1/4 in. quick-connect terminal and connect it to the male quick-connect GND (BURNER) terminal on the ignition module.
- b. Strip the other end of the wire and fasten it under the igniter bracket mounting screw. If necessary, use a shield to protect the ground wire from radiant heat.
- c. The burner serves as the common grounding area. If there is not good metal-to-metal contact between the burner and ground, run a lead from the burner to ground.

NOTE: Earth ground is not required.

Step 3: Review Normal Operating Sequence and Module Specifications.

- a. See “Operation” on page 8 and “Specifications” on page 2.

Step 4: Reset the Module.

- a. Turn the thermostat to its lowest setting.
- b. Wait one minute.

As you do the remaining steps, watch for points where operation deviates from normal. Refer to the Troubleshooting guide on page 15 to correct problems.

Step 5: Check Safety Shutoff Operation.

- Turn gas supply off.
- Set thermostat or controller above room temperature to call for heat.
- Watch for spark at pilot burner either immediately or following prepurge. See device label.
- Time spark from start to shutoff. See device label.
- On all continuous retry models, wait 5 minutes. Ignition sequence should start again followed by shutoff after 90 seconds maximum.
- Open manual gas cock and make sure no gas is flowing to pilot or main burner.
- Set thermostat below room temperature and wait one minute before continuing.

Step 6: Check Normal Operation.

- Set thermostat or controller above room temperature to call for heat.
- Make sure pilot lights smoothly when gas reaches the pilot burner.
- Make sure main burner lights smoothly without flashback.
- Make sure burner operates smoothly without floating, lifting, or flame rollout to the furnace vestibule or heat buildup in the vestibule.
- Perform a gas leak test in the appliance.

GAS LEAK TEST:

Paint the gas control gasket edges and all pipe connections downstream of the gas control, including the pilot tubing connections, with a rich soap and water solution. Bubbles indicate gas leaks. Tighten the joints and screws or replace component to stop gas leak. Recheck with soap and water solution.

- Turn the thermostat or controller below the room temperature. Make sure the main burner and pilot flames go out.

OPERATION

Module operation can be conveniently divided into two phases for the S8600 and S8610 and three phases for the S8670.

The phases are:

- Prepurge (S8670 models only)—See Fig. 10
- Trial for ignition (all models)
- Main burner operation (all models)

Fig. 9-10 summarize the normal operating sequences of all the models.

Prepurge (S8670 models Only)

When an S8670 model is used in a fan-assisted combustion system, the combustion air blower starts on a call for heat. On proof of airflow, the air proving switch

closes and energizes the S8670. When this model is used in an atmospheric system, the "Call for Heat" energizes the module.

In either case, the module first initiates a 30 second delay to allow system prepurge. After prepurge, the module starts the trial for pilot ignition sequence.

Trial for Pilot Ignition

On a "Call for Heat" (and after prepurge on S8670 models), the module energizes the spark source and the pilot valve relay simultaneously. The pilot valve opens, allowing gas to flow to the pilot burner for the ignition trial time. The spark lights the pilot flame when pilot gas is present. A flame rectification circuit confirms the presence of the pilot flame, shuts off the spark source, and energizes the main valve relay.

The S8600 family uses a two-level pilot flame proving sequence. When a sufficient flame current is sensed, the spark is turned OFF. However, the pilot flame must generate a higher level of flame current to energize the main valve. This approach assures a stable pilot flame to support reliable burner lightoff. If the pilot flame is weak or unstable, the spark may turn back ON. However, the trial for pilot ignition will not exceed the stated ignition trial time

Main Burner Operation

When the main valve opens, gas flows to the main burner where it is lit by the pilot flame. There is a short flame stabilization period as the main valve opens to allow the pilot flame to stabilize as the main gas lights. The system is now in the run mode with the presence of the pilot flame continuously monitored by the flame rectification circuit. If the pilot flame goes out, the control senses loss of pilot flame and shuts off both the pilot valve relay and the main valve relay. Flow of gas to pilot and main burners stops as the valves close.

FAILED TRIAL FOR PILOT IGNITION**Lockout Models—S8600B,H; S8610B,H; S8670D,J**

Lockout models provide a single trial for pilot ignition sequence. If the pilot flame is not lit and sensed before the end of the ignition trial time, the control shuts off the pilot valve (100% shutoff) and goes to lockout. The control remains in lockout until power to the control is cycled by the system thermostat or by removing and restoring system power.

Continuous Retry Models—S8600C,M; S8610C,M; S8670E,J

Continuous retry models provide multiple trials for ignition. If the pilot is not lit or sensed before the end of the trial for ignition time, the control shuts off the spark and pilot gas (100% shutoff). There is a 5 minute delay before another ignition sequence is initiated. The pattern of ignition sequence followed by a 5 minute delay continues until the pilot lights and is proved or the "Call for Heat" ends. The 5 minute delay time can be bypassed by cycling the system thermostat or removing and restoring system power.

OPERATING SEQUENCE - PREPURGE MODELS
S8760 E, K = RETRY
S8670 D, J = LOCKOUT

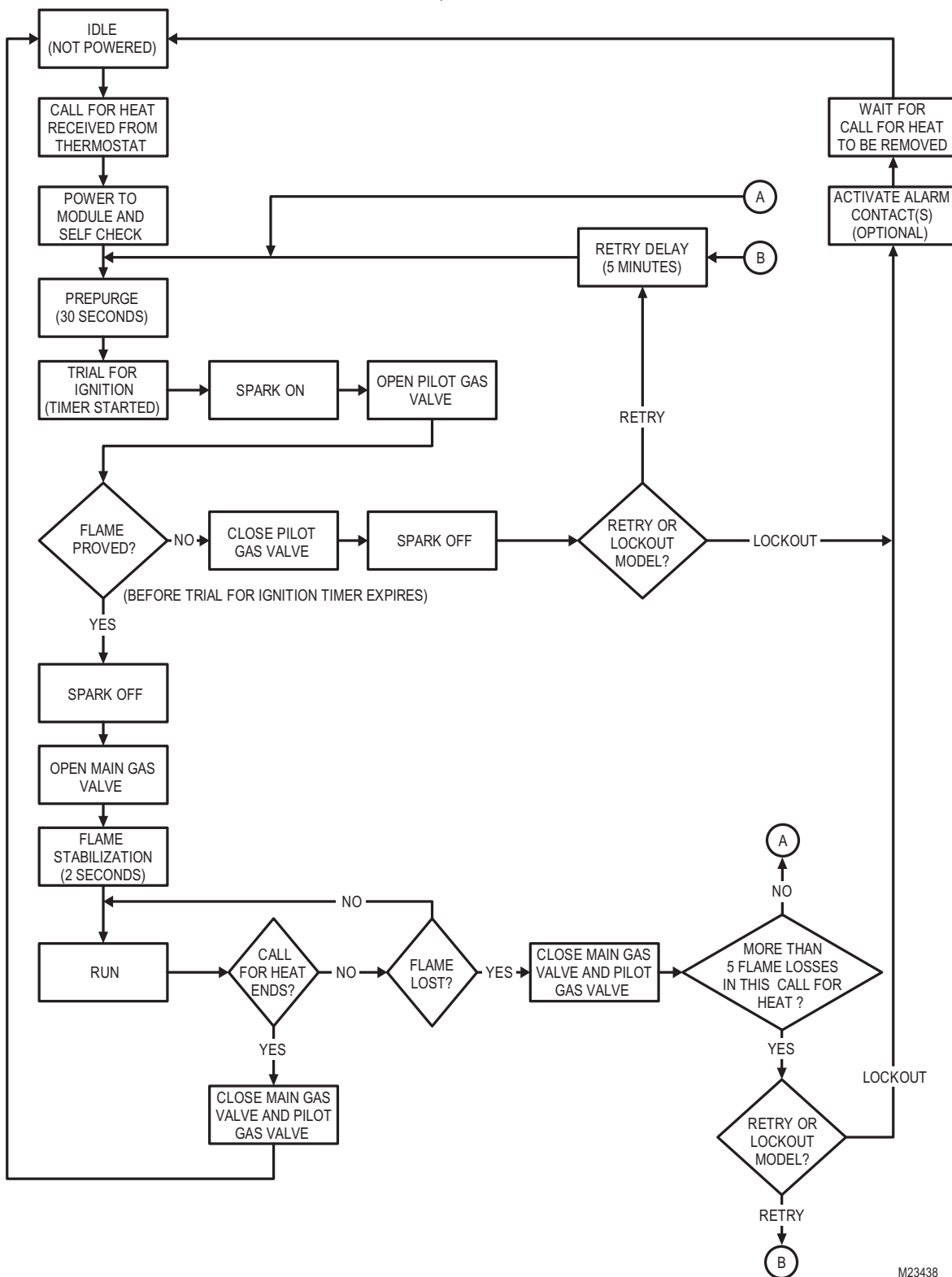

M23438

Fig. 10. Normal Operating Sequence for Prepurge Models.

TROUBLESHOOTING

WARNING

Fire, Explosion, or Electrical Shock Hazard.
Can cause severe injury, death or property damage.
 Do not attempt to modify the physical or electrical characteristics of this device in any way. Replace it if troubleshooting indicates a malfunction.

IMPORTANT

1. The following service procedures are provided as a general guide. Follow appliance manufacturer's service instructions if available.
2. Meter readings between the gas control and ignition control must be taken within the trial for ignition period. Once the ignition control shuts off, lockout models must be reset by setting the thermostat down for at least 30 seconds before continuing. On retry models, wait for retry or reset at the thermostat.
3. If any component does not function properly, make sure it is correctly installed and wired before replacing it.
4. The ignition module cannot be repaired. If it malfunctions, it must be replaced.
5. Only trained, experienced service technicians should service intermittent pilot systems.
6. After troubleshooting, check out the system again to be sure it is operating normally.

General troubleshooting process is as follows:

1. Refer to "LED Status and Troubleshooting" on page 12 for LED status codes.
2. Perform the "Checkout" on page 7 as the first step in troubleshooting.
3. Check the troubleshooting guide (Fig. 13) to pinpoint the cause of the problem.
4. If troubleshooting indicates an ignition problem, see Ignition System Checks below to isolate and correct the problem.
5. Following troubleshooting, perform the "Checkout" on page 7 again to be sure system is operating normally.

Ignition System Checks

Step 1: Check ignition cable.

Make sure:

- Ignition cable does not run in contact with any metal surfaces.
- Ignition cable is no more than 36 in. (0.9 m) long.
- Connections to the ignition module and to the igniter or igniter-sensor are clean and tight.
- Ignition cable provides good electrical continuity.

STEP 2: Check ignition system grounding.

Nuisance shutdowns are often caused by a poor or erratic ground.

A common ground is required for the module and the pilot burner bracket.

- Check the ground circuit from the GND(BURNER) terminal on the module to the pilot burner. Make sure connections are clean and tight. If the wire is damaged or deteriorated, replace it with 14- to 18-gauge, moisture-resistant, thermoplastic insulated wire with 221°F (105°C) minimum rating.
 - If the flame rod or bracket is bent out of position, restore to correct position.

STEP 3: Check spark ignition circuit. You will need a short jumper wire made from ignition cable or other heavily insulated wire.

- Close the manual gas valve.
- Disconnect the ignition cable at the SPARK terminal on the module.

WARNING

Electrical Shock Hazard.
Can cause severe injury, death or property damage.
 When performing the following steps, do not touch stripped end of jumper or SPARK terminal. The ignition circuit generates over 10,000 volts and electrical shock can result.

- Energize the module and immediately touch one end of the jumper firmly to the GND terminal on the module. Move the free end of the jumper slowly toward the SPARK terminal until a spark is established.
- Pull the jumper slowly away from the terminal and note the length of the gap when sparking stops. Check Table 5 below.

Table 5. Arc Troubleshooting.

Arc Length	Action
No arc or arc less than 1/8 in. (3 mm)	Check external fuse, if provided. Verify power at the module's input terminal. Replace control if fuse and power are okay.
Arc 1/8 in.(3 mm) or longer	Voltage output is okay.

STEP 4: Check pilot and main burner lightoff.

- Set the thermostat to call for heat.
- Watch the pilot burner during the ignition sequence. See if:
 - Ignition spark continues after the pilot is lit.
 - The pilot lights and the spark stops, but main burner does not light.
 - S8600 B,H; S8610 B,H; S8670 D,J only: The pilot lights, the spark stops and main burner lights, but the system shuts down.
- If so, ensure adequate flame current as follows.
 - Turn off furnace at circuit breaker or fuse box.
 - Clean the flame rod with emery cloth.
 - Make sure electrical connections are clean and tight. Replace damaged wire with moisture-resistant No. 18 wire rated for continuous duty up to 221°F (105°C).
 - Check for cracked ceramic insulator, which can cause short to ground, and replace igniter-sensor if necessary.
 - At the gas control, disconnect main valve wire from the MV terminal.

- Turn on power and set thermostat to call for heat. The pilot should light but the main burner will remain off because the main valve actuator is disconnected.
- Check the pilot flame. Make sure it is blue, steady and envelops 3/8 to 1/2 in. (10 to 13 mm) of the flame rod. See Fig. 11 for possible flame problems and their causes.
- If necessary, adjust pilot flame by turning the pilot adjustment screw on the gas control clockwise to decrease or counterclockwise to increase pilot flame. Following adjustment, always replace pilot adjustment cover screw and tighten firmly to assure proper gas control operation.
- Set thermostat below room temperature to end call for heat.





APPEARANCE	CAUSE
<p>SMALL BLUE FLAME</p> 	<p>CHECK FOR LACK OF GAS FROM:</p> <ul style="list-style-type: none"> ✘ CLOGGED ORIFICE FILTER ✘ CLOGGED PILOT FILTER ✘ LOW GAS SUPPLY PRESSURE ✘ PILOT ADJUSTMENT AT MINIMUM
<p>LAZY YELLOW FLAME</p> 	<p>CHECK FOR LACK OF AIR FROM:</p> <ul style="list-style-type: none"> ✘ DIRTY ORIFICE ✘ DIRTY LINT SCREEN, IF USED ✘ DIRTY PRIMARY AIR OPENING, IF THERE IS ONE ✘ PILOT ADJUSTMENT AT MINIMUM
<p>WAVING BLUE FLAME</p> 	<p>CHECK FOR:</p> <ul style="list-style-type: none"> ✘ EXCESSIVE DRAFT AT PILOT LOCATION ✘ RECIRCULATING PRODUCTS OF COMBUSTION
<p>NOISY LIFTING BLOWING FLAME</p> 	<p>CHECK FOR:</p> <ul style="list-style-type: none"> ✘ HIGH GAS PRESSURE
<p>HARD SHARP FLAME</p> 	<p>THIS FLAME IS CHARACTERISTIC OF MANUFACTURED GAS</p> <p>CHECK FOR:</p> <ul style="list-style-type: none"> ✘ HIGH GAS PRESSURE ✘ ORIFICE TOO SMALL

Fig. 11. Examples of unsatisfactory pilot flames.

- Recheck ignition sequence as follows.
 - Reconnect main valve wire.
 - Set thermostat to call for heat.
 - Watch ignition sequence at burner.
 - If spark still doesn't stop after pilot lights, replace ignition control.
 - If main burner doesn't light or if main burner lights but system locks out, check the control, ground wire and gas control as described in "Troubleshooting" on page 11 and refer to the Troubleshooting Guide (Fig. 13).

LED Status and Troubleshooting

The control has two LEDs; one for flame sensing and one for system status:

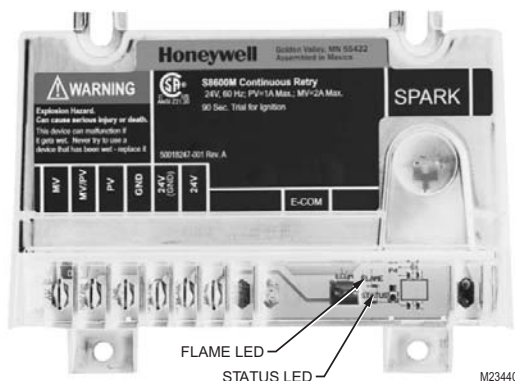

Fig. 12. Location of LEDs.

- **Flame LED (Yellow)**
 - Indicates flame presence and strength. See Table 6.
- **Status LED (Green)**
 - Indicates system operation status and error conditions. See Table 7 and Table 8 for status specific to each model.

Table 6. Yellow LED Flame Codes.

Yellow LED Flash Code ^a	Indicates	Recommended Service Action
Heartbeat	Normal Flame Signal	Not applicable
2	Weak Flame Signal— System will operate reliably but flame signal is less than desired. NOTE: This indication may flash temporarily during or shortly after lightoff on some applications.	Perform routine maintenance to assure optimum flame signal.
1	Marginal Flame Signal (less than 1.1µA)— System may not operate reliably over time. Service call recommended. NOTE: This indication may flash temporarily during or shortly after lightoff on some applications.	Check gas supply, pilot burner, flame sense wiring, contamination of flame rod, burner ground connection.
OFF	No Flame or Flame Signal below minimum threshold for system operation.	Not applicable

^a Flash Code Descriptions:

- Heartbeat: Constant 1/2 second bright, 1/2 second dim cycles.
- The flash code number signifies that the LED flashes X times at 2Hz, remains off for two seconds, and then repeats the sequence.

Table 7. Continuous Retry Models C, M, E, and K Only—Green LED Status Codes.

Green LED Flash Code (X + Y) ^a	Indicates	Next System Action	Recommended Service Action
OFF	No "Call for Heat"	Not applicable	None
Flash Fast	Startup - Flame sense calibration	Not applicable	None
Heartbeat	Normal operation	Not applicable	None
2	5 minute Retry Delay - Pilot flame not detected during trial for ignition	Initiate new trial for ignition after retry delay completed.	If system fails to light on next trial for ignition check gas supply, pilot burner, spark and flame sense wiring, flame rod contaminated or out of position, burner ground connection.
3	Recycle - Flame failed during run	Initiate new trial for ignition. Flash code will remain through the ignition trial until flame is proved.	If system fails to light on next trial for ignition, check gas supply, pilot burner, flame sense wiring, contamination of flame rod, burner ground connection.
4	Flame sensed out of sequence	If situation self corrects within 10 seconds, control returns to normal sequence. If flame out of sequence remains longer than 10 seconds, control goes to Flash code 6+4 (see below).	Check for pilot flame. Replace gas valve if pilot flame present. If no pilot flame, cycle "Call for Heat." If error repeats, replace control.
7	Flame sense leakage to ground	Control remains in wait mode. When the fault corrects, control resumes normal operation after a one minute delay.	Check flame sense lead wire for damage or shorting. Check that flame rod is in proper position. Check flame rod ceramic for cracks, damage or tracking.
8	Low secondary voltage supply - (below 15.5 Vac)	Control remains in wait mode. When the fault corrects, control resumes normal operation after a one minute delay.	Check transformer and AC line for proper input voltage to the control. Check with full system load on the transformer.
6+2	5 minute Retry Delay - On every third retry on the same "Call for Heat"	Initiate new trial for ignition after retry delay completed.	Check gas supply, pilot burner, spark and flame sense wiring, flame rod contaminated or out of position, burner ground connection.
6+3	On every 6th flame failure during run on the same "Call for Heat"	5 minute retry delay, then initiate new trial for ignition.	Check gas supply, pilot burner, flame sense wiring, contamination of flame rod, burner ground connection.
6+4	Flame sensed out of sequence - longer than 10 seconds	Control waits until flame is no longer sensed and then goes to soft lockout. Flash code continues. Control auto resets from soft lockout after one hour.	Check for pilot flame. Replace gas valve if pilot flame present. If no pilot flame, cycle "Call for Heat." If error repeats, replace control.
ON	Soft lockout due to error detected during self check sequences	Control auto resets from soft lockout after one hour.	Reset by cycling "Call for Heat." If error repeats, replace the control.

^a Flash Code Descriptions:

- Flash Fast: rapid blinking.
- Heartbeat: Constant ½ second bright, ½ second dim cycles.
- A single flash code number signifies that the LED flashes X times at 2Hz, remains off for two seconds, and then repeats the sequence.
- X + Y flash codes signify that the LED flashes X times at 2Hz, remains off for two seconds, flashes Y times at 2Hz, remains off for three seconds, and then repeats the sequence.

Troubleshooting Guide

Refer to the following guide for troubleshooting (Fig. 13).

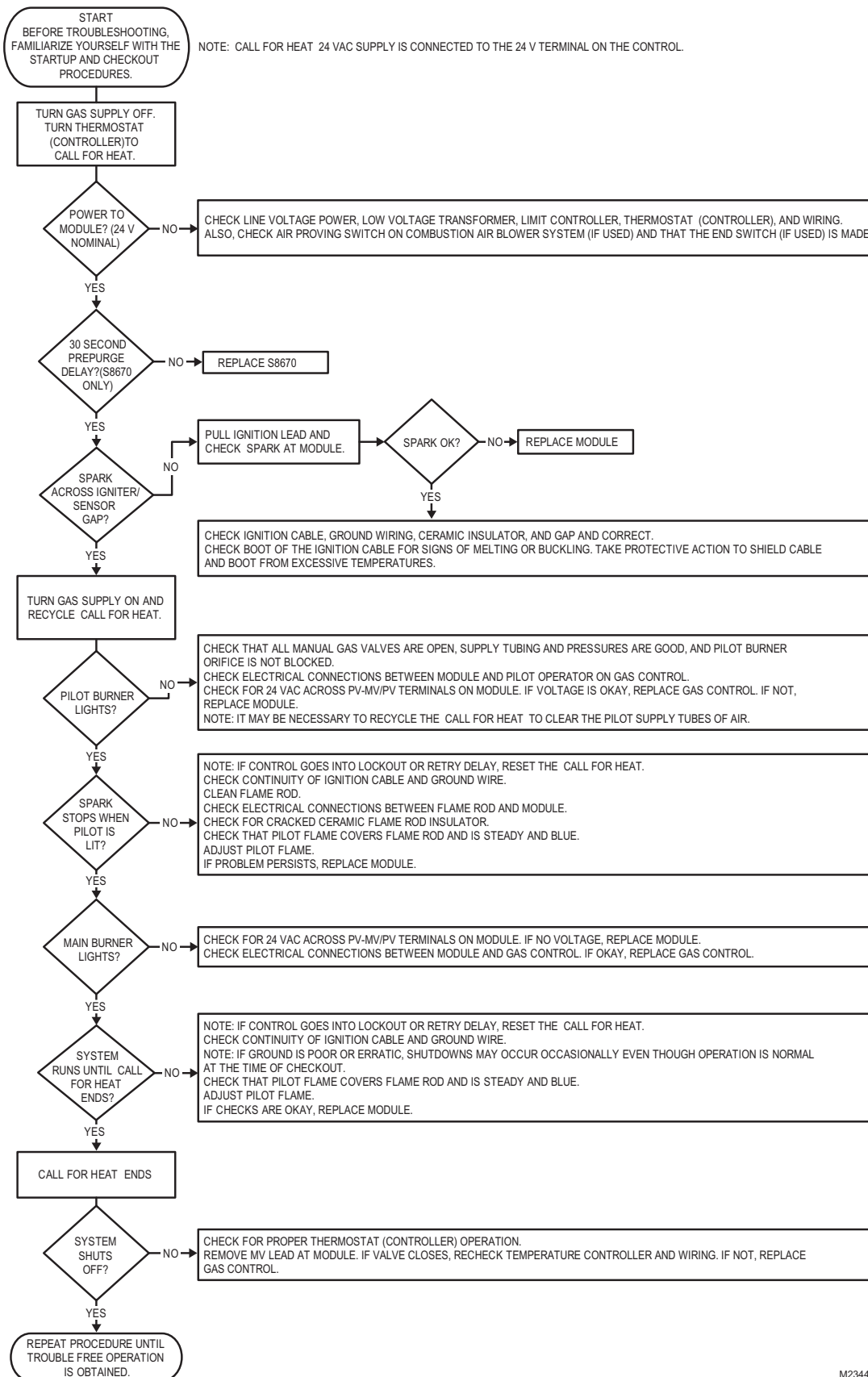

M23441

Fig. 13. Troubleshooting Guide.

TROUBLESHOOTING GUIDE

Modulating Gas Valve Motor Replacement

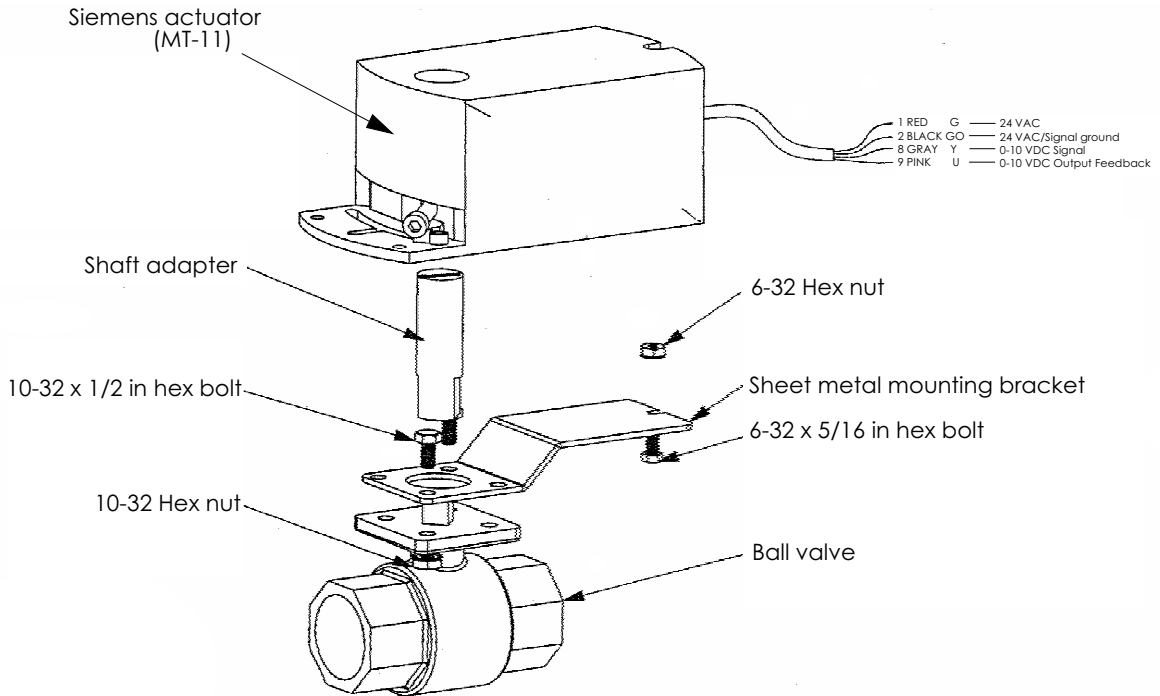

Note:

When replacing the modulating gas valve motor (MT-11), make sure the ball valve is in the closed position. Rotate the shaft adapter until the notches located on top of the ball valve and the shaft adapter indicate that the ball valve is in the closed position.

To Calibrate the Building Pressure Transducer (PT-13)

1. Remove the tubes at the Low and High pressure fittings.
2. The voltage at -COM and OUT should be 2.5 VDC. If not adjust Z (do not adjust S).
3. **Make sure the Low and High fittings are clean and clear (do not insert any sharp objects into the pressure fittings). Make sure the tubing is also clean, clear of any debris and then reinstall the tubes on the transducer. It is very important that the High tube be placed inside the building, and positioned so that air movement does not affect it. The Low side should be to atmosphere, and positioned so it is not exposed to the weather.**
4. With the use of a BACview 6 (KP-01) place the unit in the Building Pressure mode. (See the Digital Control System User Manual).
5. The voltage at -COM and OUT will vary between 0 to 5 VDC. 0 VDC means the building is in a negative pressure and should open the Outside Air/Profile and close the Return Air damper. 5 VDC means the building is in a positive pressure and should open the Return Air Damper and close the Outside Air/Profile Damper.

PT-13		
SETRA P/N	MESTEX P/N	RANGE
26510R1WBABT1C	68.0330.69	± .1 IN WC

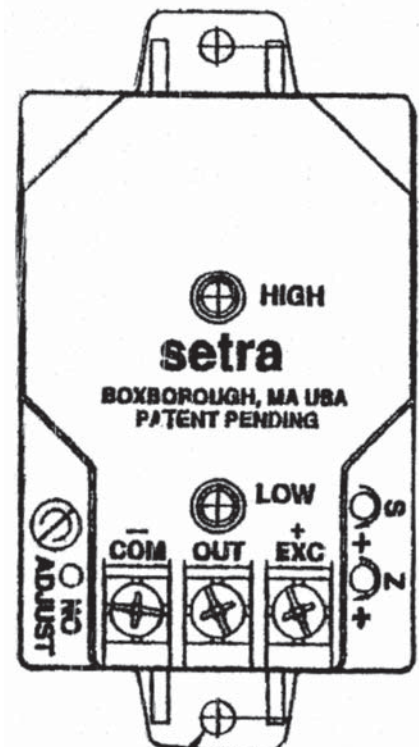

MULTIPLEXED VOLTAGE CHART

RESISTOR VALUE	RESISTOR ID	SWITCH CLOSED	OHMS IN CIRCUIT	VOLTS DC
1000	RS1	RS1,2,3,4	0	0
2000	RS2	RS2,3,4	1000	0.30
4020	RS3	RS1,3,4	2000	0.55
8060	RS4	RS3,4	3000	0.76
MULTIPLEXED VOLTAGE VALUES		RS1,2,4	4020	0.95
		RS2,4	5020	1.10
		RS1,4	6020	1.24
		RS4	7020	1.36
		RS1,2,3	8060	1.47
		RS2,3	9060	1.57
		RS1,3	10060	1.65
		RS3	11060	1.73
		RS1,2	12080	1.80
		RS2	13080	1.87
		RS1	14080	1.92
		NONE	15080	1.98
		UNPLUGGED	NA	3.30

IN-3	JUMPER	RS-04	MIXED AIR TEMP
	RE-56	RS-03	SAFETY CKT STATUS
	RE-09	RS-02	FLAME FAILURE
	SW-72	RS-01	100% OA or 100% OUTPUT
IN-4	RE-27	RS-04	BURNER STATUS
	RE-65	RS-03	FAN STATUS
	RE-12	RS-02	CLOGGED FILTER
	SW-09	RS-01	AUXILIARY UNIT ENABLE

SECTION VII - TROUBLE SHOOTING *continued*

Fan and Heat Mode

Symptom	Cause	Remedy
<p>A. Supply blower does not operate.</p>	<ol style="list-style-type: none"> 1. Low or no voltage. 2. Fuse(s) blown or circuit breaker open. 3. Customer's interlock not closed or connected. 4. Fan is disabled. 5. Time clock, night setback thermostat, or field installed controls open. 6. Freeze protection tripped (low discharge temperature). 7. Damper motor not operating, its end switch not making, or dampers binding. 8. Overload protection on motor starter tripped. 9. Belts loose or broken. 10. Motor may be burned or incorrectly wired. 11. Firestat and/or smoke detector contacts not closed. 12. Bearing seized on shaft. 13. DO-1 on UC-01 not energized. 	<ol style="list-style-type: none"> 1. Check power source. 2. Check and/or replace. 3. Close or connect customer interlock. 4. Enable fan. 5. Check time clock, night setback thermostat and field installed controls for proper settings. 6. Reset freeze stat by interrupting power. Check for proper setting and burner operation. 7. Check for power at damper motor and that end switch has been wired correctly. End switch should be wired N.O. (normally open). Check that linkage is free and not binding. 8. Reset the starter by pushing red button on starter, check amp draw. 9. Turn power off and check belts. 10. Turn power off and check motor and wiring. 11. Check firestat and smoke detector for correct settings and operation. 12. Turn power off and check. 13. See Digital Control System User Manual.
<p>B. Burner motor (MT-08) does not run or operate correctly, and supply fan is enabled.</p>	<ol style="list-style-type: none"> 1. Auxiliary switch on starter (ST-01) not closed. 2. Heat mode is disabled. 3. Fan starter relay not closed. 4. Outside air temperature higher than heating economizer setpoint. 5. Safety and limit circuits open. 6. Safety circuit status relay not closed. 7. Burner motor may be defective or incorrectly wired. 8. Burner blower motor control (BC-01) open. 9. Burner status relay not closed. 10. DO-2 on UC-01 not energized. 11. Burner motor staying in high speed. 	<ol style="list-style-type: none"> 1. Check auxiliary switch circuit wiring and contact. 2. Enable the heat mode. 3. Check for power or replace. 4. Check setpoint. 5. Close safety and limit circuits. 6. Check for power or replace. 7. Turn power off and check motor and wiring. 8. Check wiring and/or replace control. See Section XI for circuit analysis of burner motor. 9. Check for power or replace. 10. See Digital Control System User Manual. 11. Check VDC at AO-3 output and replace UC-01 if defective. See Section XI for circuit analysis of burner motor.

(Refer to Digital Control System User Manual for additional troubleshooting suggestions)

SECTION VII - TROUBLE SHOOTING *continued*

Fan and Heat Mode

Symptom	Cause	Remedy
C. No voltage at ignition control (RE-02) input terminals.	<ol style="list-style-type: none"> 1. See burner motor does not operate Cause #1, 2, 3, 4, 5, 6, 7, 8, 9 and 10. 2. Check for 24 VAC at TR-08 terminals. 3. The red light is illuminated on the tach monitor (TM-01). 	<ol style="list-style-type: none"> 1. See burner motor does not operate Remedy #1, 2, 3, 4, 5, 6, 7, 8, 9 and 10. 2. Prove the power source. 3. Check wiring. See Section XI for circuit analysis of burner motor.
D. Ignition control (RE-02) goes into safety shutdown (Lockout).	<ol style="list-style-type: none"> 1. See technical data sheets on ignition control. 	<ol style="list-style-type: none"> 1. Determine the cause of lockout. Reset the ignition control.
E. Pilot and/or burner does not light after prepurge has timed out and voltage is present on ignition control (RE-02) input terminals.	<ol style="list-style-type: none"> 1. Manual pilot/gas shut-off valve closed. 2. Inlet gas pressure lower than minimum gas pressure required. 3. No gas through pilot regulator with sufficient inlet gas pressure (if applicable). 4. No gas flow through gas valve. 5. Type of gas supplied (natural gas or propane) different than shown on unit rating plate. 6. Flame detection system not sensing pilot/burner flame. (See section for servicing burner). 7. No voltage to spark rod. 	<ol style="list-style-type: none"> 1. Slowly open valve. 2. Increase gas pressure. 3. Clear obstruction in vent orifice or line, replace if defective. 4. Check for proper installation, and voltage. Correct or replace if defective. 5. Connect to proper fuel supply or contact factory for field conversion parts. 6. Flame Rod – Assure rod is in pilot/burner flame, check wiring, and flame rod. 7. Check wiring. Replace RE-02 if defective.
F. If pilot and/or burner does not light after pre-purge has timed out and there is no voltage at ignition control (RE-02) output terminals.	<ol style="list-style-type: none"> 1. See technical data sheets on ignition control. 	<ol style="list-style-type: none"> 1. Check wiring and replace if defective.
G. If there is no heat with pilot OK (if applicable) and voltage is present at ignition control (RE-02) output terminals.	<ol style="list-style-type: none"> 1. Manual gas shut-off valve closed on VG-02. 2. No gas on outlet side of gas valve VG-02 regulator with proper inlet pressure. 3. No gas on outlet side of modulating motor (MT-11) with proper inlet pressure, and 0-10 VDC signal is correct. 4. Burner does not modulate and 0-10 VDC signal is not present. 	<ol style="list-style-type: none"> 1. Turn heat off-on switch to the off position. Slowly open all manual gas shut-off valves. 2. Check for correct wiring and power. Replace if defective. 3. Check wiring, voltage, and adjustment. Correct wiring or replace if defective. (See troubleshooting guide and Section XI). 4. Check wiring at (AO-01) and replace (UC-01) if defective.

(Refer to Digital Control System User Manual for additional troubleshooting suggestions)

SECTION VII - TROUBLE SHOOTING *continued*

Fan and Heat Mode

Symptom	Cause	Remedy
H. Burner will not respond to temperature.	1. For DDC Control Systems.	1. See Digital Control System User Manual and Section XI Circuit Analysis for gas and burner motor.
I. Return air and outside air damper operation not functioning properly (see sequence of operation for damper control).	1. Building Pressure Transducer (PT-13) or Damper Control Potentiometer defective or not calibrated. 2. Building Pressure Transducer (PT-13) or Damper Control Potentiometer not wired correctly. 3. Building Pressure Transducer (PT-13) or Damper Control Potentiometer not installed correctly. 4. Unit Control Module (UC-01) defective. 5. Unit Control Module (UC-01) not wired correctly. 6. Damper motor defective. 7. Dampers binding and/or loose.	1. Check and/or replace components. See section on trouble shooting PT-13. 2. Check wiring. 3. Install correctly. See section on trouble shooting PT-13. 4. Check and/or replace. Contact Factory. 5. Check wiring. 6. Check and/or replace. 7. Check and repair as necessary.

(Refer to Digital Control System User Manual for additional troubleshooting suggestions)

SECTION VII - TROUBLE SHOOTING *continued*

Modulating Discharge Temperature (MDT or VDT-EXPERT) Controls

Portions reproduced with permission from Maxitrol

Symptom	Possible Cause	Field Test	Remedy
A. No Gas Flow with DO-2 on UC-01 energized.	<ol style="list-style-type: none"> 1. Main gas valve improperly installed. 2. Defective main gas valve. 	<ol style="list-style-type: none"> 1. Arrow on side of valve should point in direction of gas flow. 2. Check for 24 VAC. 	<ol style="list-style-type: none"> 1. Install properly. 2. Replace valve if necessary.
B. No Gas Flow or Continuous Low Fire on MT-11 (Electronics Problem).	<ol style="list-style-type: none"> 1. No voltage to modulating motor (MT-11). 2. Incorrect VDC output voltage on UC-01. 	<ol style="list-style-type: none"> 1. Check for 24V AC at TR-08 terminals. 2. Check DC Voltage on AO-1. 	<ol style="list-style-type: none"> 1. Prove the power source. See Section XI. 2. Contact Factory.
C. Continuous Low Fire (Electronics OK).	<ol style="list-style-type: none"> 1. Short circuit or open circuit in modulating motor (MT-11). 	<ol style="list-style-type: none"> 1. Measure VDC across valve terminals. 	<ol style="list-style-type: none"> 1. Replace MT-11 if proper voltage is measured. (See troubleshooting guide and Section XI).
D. Continuous High Fire (Electronics Problem).	<ol style="list-style-type: none"> 1. Open circuit in Outside Air Temperature Sensor (TS-01) or Discharge Air Temperature Sensor (TS-03) circuit or wiring. 2. Incorrect VDC output voltage on UC-01. 	<ol style="list-style-type: none"> 1. Check Outside Air Temperature Sensor (TS-01) or Discharge Air Temperature Sensor (TS-03) for open internal circuit. See Section XII for Thermistor curve. 2. Check DC voltage on AO-1. 	<ol style="list-style-type: none"> 1. Replace Outside Air Temperature Sensor (TS-01) or Discharge Air Temperature Sensor (TS-03). 2. Contact factory.
E. Continuous High Fire (Electronics OK).	<ol style="list-style-type: none"> 1. Foreign object holding ball valve open. 	<ol style="list-style-type: none"> 1. Remove and inspect valve and valve seat. 	<ol style="list-style-type: none"> 1. Clean seat. Clean valve or replace if necessary.
F. Incorrect Maximum Fire	<ol style="list-style-type: none"> 1. Inlet pressure too low. 2. Incorrect outlet pressure adjustment of Pressure Regulator. 	<ol style="list-style-type: none"> 1. Read pressure at inlet to modulating valve using a manometer with unit operating at full fire. Pressure should be equal to the sum of outlet pressure setting plus pressure drop of the valve. 2. Read manifold pressure using manometer and compare with pressure stated on the rating plate. 	<ol style="list-style-type: none"> 1. Increase inlet pressure if possible. 2. See valve adjustments in Section XI.
G. Incorrect Discharge Air Temperature	<ol style="list-style-type: none"> 1. Unit Enable Potentiometer (MP-15) not set correctly. 2. Discharge Air Temperature Sensor (TS-03) not reading correctly. 3. The Heating Discharge Air Setpoint on VDT-EXPERT Control System is not set correctly. 	<ol style="list-style-type: none"> 1. Check setpoint on Unit Enable Potentiometer (MP-15). 2. Check Discharge Air Temperature Sensor (TS-03) and wiring. See Section XII for Thermistor curve. 3. Check setpoint with BACview or PC. 	<ol style="list-style-type: none"> 1. Change to correct setpoint setting. 2. If readings are not correct, replace Discharge Air Temperature Sensor (TS-03) or repair wiring. 3. Change to correct setpoint. See Digital Control System User Manual.

(Refer to Digital Control System User Manual for additional troubleshooting suggestions)

SECTION VII - TROUBLE SHOOTING *continued*

Modulating Room Temperature (MRT, MRT-PRO or MRT-EXPERT) Controls Portions reproduced with permission from Maxitrol Company

Symptom	Possible Cause	Field Test	Remedy
A. No Gas Flow with DO-2 on UC-01 energized.	<ol style="list-style-type: none"> 1. Main gas valve improperly installed. 2. Defective main gas valve. 	<ol style="list-style-type: none"> 1. Arrow on side of valve should point in direction of gas flow. 2. Check for 24 VAC. 	<ol style="list-style-type: none"> 1. Install properly. 2. Check and/or replace valve.
B. No Gas Flow or Continuous Low Fire on MT-11 (Electronics OK).	<ol style="list-style-type: none"> 1. Open or short circuit in modulating motor (MT-11). 	<ol style="list-style-type: none"> 1. Measure VDC across valve terminals. 	<ol style="list-style-type: none"> 1. Replace MT-11 if proper voltage is measured. (See troubleshooting guide and Section XI).
C. Continuous Low Fire (Electronics Problem).	<ol style="list-style-type: none"> 1. No voltage to control valve (MT-11). 2. Incorrect VDC output voltage on UC-01. 	<ol style="list-style-type: none"> 1. Check for 24V AC at TR-08. 2. Check voltage on AO-01. 	<ol style="list-style-type: none"> 1. Prove the power source. See Section XI. 2. Consult factory.
D. Continuous Minimum Discharge Air Temperature.	<ol style="list-style-type: none"> 1. Incorrect room temperature. 	<ol style="list-style-type: none"> 1a. Check Outside Air Sensor (TS-01), Space Temperature Sensor (TS-02) and Discharge Air Sensor (TS-03) for correct readings. See Section XII for Thermistor curve, use a BACview 6 to read the space temperature (TS-02). 1b. Check Space Temperature Sensor (TS-02) setpoint. 1c. Check Heating Occupied and/or Unoccupied setpoint. 	<ol style="list-style-type: none"> 1a. Replace Sensors if reading is incorrect or correct wiring. 1b. Change to correct setpoint. 1c. Change to correct setpoint.
E. Incorrect Maximum or Minimum Discharge Air Temperature.	<ol style="list-style-type: none"> 1. Maximum or minimum heating discharge temperature setpoint not set correctly. 	<ol style="list-style-type: none"> 1. Install a BACview 6 or PC. 	<ol style="list-style-type: none"> 1. Change to correct setpoints.
F. Continuous High Fire (Electronics OK).	<ol style="list-style-type: none"> 1. Foreign material holding ball valve open. 	<ol style="list-style-type: none"> 1. Remove and inspect valve and seat. 	<ol style="list-style-type: none"> 1. Clean, replace valve and/or seat if necessary.
G. Continuous High Fire (Electronics Problem).	<ol style="list-style-type: none"> 1. Open circuit in Outside Air Temperature Sensor (TS-01) or Discharge Air Temperature Sensor (TS-03) circuit or wiring. 2. Incorrect VDC output voltage on UC-01). 	<ol style="list-style-type: none"> 1. Check Outside Air Temperature Sensor (TS-01) or Discharge Air Temperature (TS-03) for open internal circuit. See Section XII for Thermistor curve. 2. Check voltage on AO-01. 	<ol style="list-style-type: none"> 1. Replace Outside Air Temperature Sensor (TS-01) or Discharge Air Temperature Sensor (TS-03). 2. Contact factory.

(Refer to Digital Control System User Manual for additional troubleshooting suggestions)

SECTION VII - TROUBLE SHOOTING *continued*

Modulating Room Temperature (MRT, MRT-PRO or MRT-EXPERT) Controls Portions reproduced with permission from Maxitrol Company

Symptom	Possible Cause	Field Test	Remedy
H. Incorrect High Fire.	<ol style="list-style-type: none"> 1. Inlet Pressure too low. 2. Incorrect outlet pressure adjustment of Pressure Regulator. 	<ol style="list-style-type: none"> 1. Read pressure at inlet to modulating valve using a manometer with unit operating at full fire. Pressure should be equal to the sum of outlet pressure setting plus pressure drop of the valve 2. Read manifold pressure using manometer and compare with pressure stated on the rating plate. 	<ol style="list-style-type: none"> 1. Increase inlet pressure if possible or change to larger valve. Consult factory about possibility of using special spring to reduce pressure drop on selected installations. 2. See valve adjustments in Section XI.
I. Continuous Maximum Discharge Air Temperature.	<ol style="list-style-type: none"> 1. Open circuit in Space Temperature Sensor (TS-02) or Discharge Air Temperature Sensor (TS-03). 	<ol style="list-style-type: none"> 1. Measure resistance per Thermistor Curve in Section XII. Use a BACview 6 to read the space temperature (TS-02). 	<ol style="list-style-type: none"> 1. If readings are incorrect, replace Space Temperature Sensor (TS-02) or Discharge Air Temperature Sensor (TS-03) or repair wiring.
J. Incorrect Space Temperature.	<ol style="list-style-type: none"> 1. Incorrect Maximum Heating Discharge Temperature Setpoint. 2. Incorrect Minimum Heating Discharge Temperature Setpoint. 3. Incorrect space temperature setpoint. 4. Insufficient burner capacity. 	<ol style="list-style-type: none"> 1. Check to see if heater is delivering at Maximum Discharge Setpoint. 2. Check to see if heater is delivering at Minimum Discharge Setpoint. 3a. Check Unit Enable Potentiometer (MP-15) Setpoint. 3b. Check heating Occupied and/or Unoccupied setpoint. 4. Check to see if heater is operating at high fire. 	<ol style="list-style-type: none"> 1. If desired temperature is not reached, increase Maximum Heating Discharge Temperature Setpoint. 2. If desired Space Temperature is not reached, increase Minimum Heating Discharge Setpoint. 3a. Change to correct setpoint. 3b. Change to correct setpoint. 4. If desired Space Temperature is not reached with heater at high fire, it may be undersized. Consult Factory.

(Refer to Digital Control System User Manual for additional troubleshooting suggestions)

Control circuits external to MRT Controls can cause burner malfunction.

Always check manual valve to be certain gas is on, and check limit controls for normal operation.

SECTION VII - TROUBLE SHOOTING *continued*

Cooling Mode

Symptom	Cause	Remedy
A. There is no voltage at cooling relays (RE-34) (RE-35) and/or (RE-33) and fan is enabled.	<ol style="list-style-type: none"> 1. Cooling mode is disabled. 2. Auxiliary switch on starter (ST-01) is not closed. 3. Cooling Changeover and/or Economizer Setpoints not set correctly. 4. DO-3 and/or DO-4 are not energized. 5. Open circuit in TS-01 and/or TS-03. 	<ol style="list-style-type: none"> 1. Enable the cooling mode. 2. Check auxiliary circuit wiring and contact. 3. Change to correct setpoints. See Digital Control User Manual. 4. See Digital Control System User Manual. 5. Measure resistance per Thermistor Curve in Section XII, replace if necessary.
B. Cooling relays (RE-34) (RE-35) and/or (RE-33) are energized and condensing unit or evaporative cooler is not on.	<ol style="list-style-type: none"> 1. Cooling relays (RE-34) (RE-35) and/or (RE-33) contacts are not closed. 2. Cooling relays (RE-34) (RE-35) and/or (RE-33) contacts are not wired correctly. 3. Compressors or evaporative pump not running. 	<ol style="list-style-type: none"> 1. Check and/or replace. 2. Correct wiring. 3. See Troubleshooting Guide for your condensing unit or evaporative cooler.
C. Incorrect Space Temperature.	<ol style="list-style-type: none"> 1. Incorrect Maximum Cooling Discharge Temperature Setpoint. 2. Incorrect Minimum Cooling Discharge Temperature Setpoint. 3. Unit Enable Potentiometer (MP-15) not set correctly. 4. Cooling Occupied and/or Unoccupied setpoints not set correctly. 5. Insufficient cooling. 6. Condensing section or evaporative cooler is not operating correctly. 	<ol style="list-style-type: none"> 1. Decrease Maximum Cooling Discharge Temperature Setpoint. See Digital Control System User Manual. 2. Decrease Minimum Cooling Discharge Temperature Setpoint. See Digital Control System User Manual. 3. Change to correct setpoints. See Digital Control System User Manual. 4. Change to correct setpoints. See Digital Control System User Manual. 5. If desired Space Temperature is not reached and cooling is at full capacity, it may be undersized. 6. See Troubleshooting Guide for your condensing unit or evaporative cooler.

(Refer to Digital Control System User Manual for additional troubleshooting suggestions)

SECTION VIII – FLUE GAS ANALYSIS

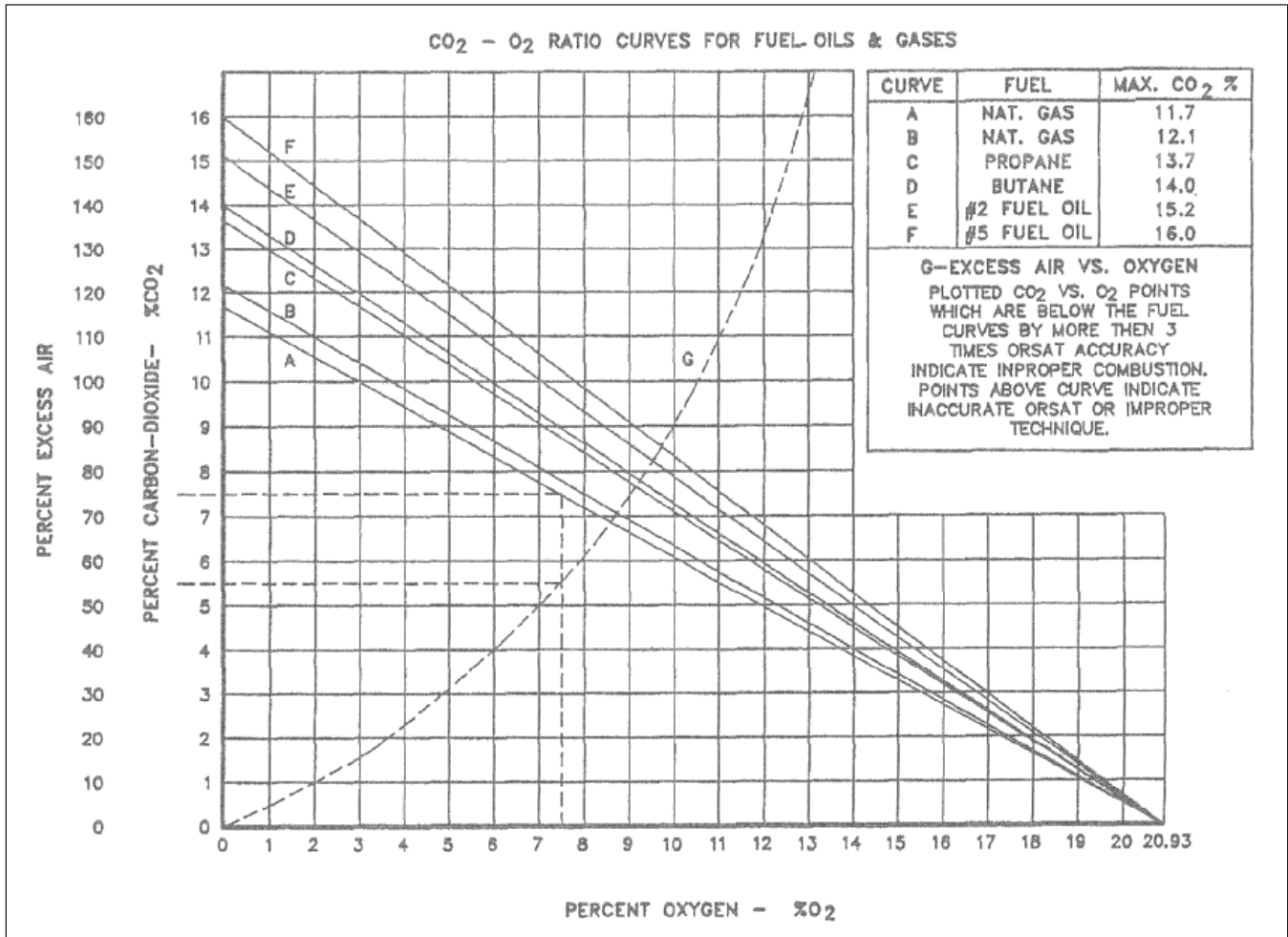

SECTION IX – MAINTENANCE SCHEDULE AND LUBRICATION REQUIREMENTS

WARNING: Failure to comply with the general safety information may result in extensive property damage, severe personal injury or death.

Periodic maintenance is essential to the efficient operation and extended service life of this equipment. Failure to provide maintenance as recommended may void the equipment warranty.

A. Maintenance Schedule

1. Daily

- a. Check gauges, monitors, instruments and equipment settings.

2. After 8 hours of operation

- a. Check that fan belts are tight and sheaves are aligned. The fan belts can be checked every 30 days after the first 60 days of new belt run-in. **CAUTION: Do not overtighten belts.**
- b. Check set screws and bolts on the fan(s), bearings, couplings and burner assembly.
- c. Check gas pressure at regulator.

3. After 48 hours of operation, check bearings for any unusual vibration or excessive temperature.

4. Monthly

- a. Check all valves, piping and connections for leaks.
- b. Check the flame signal and safety lockout circuit.
- c. Check the fuel pressure in the fuel supply line to each heater.
- d. Check the burner manifold pressure and draft.
- e. Do a flue gas analysis.
- f. Inspect filters. Clean or replace as necessary.
- g. Inspect the main fan bearings, lubricate if necessary. See following section on bearing maintenance.
- h. Check all dampers, damper actuators and linkages. Adjust and tighten if necessary.
- i. Ensure that there are no obstructions blocking the discharge air opening, condensor fans, coil(s) or heater.
- j. Inspect the area and make sure that no combustible or hazardous material has been stored within the clearances as shown on the unit nameplate.
- k. Check and clear all air sensing tubes and fittings. **CAUTION: Remove tubes from switches, and transducers before using compressed air to blow through tubing.**
- l. Test ignition spark. There should be a continuous spark for 15 seconds with pilot gas turned off.

5. Quarterly

- a. Complete the monthly maintenance schedule.
- b. Inspect all drives for proper belt tension and wear.
- c. Check the alignment of the sheaves and adjust if necessary.
- d. Inspect all bearings set screws for tightness and lubricate bearings if necessary.
- e. Check the flame and spark rod wiring and connection.

- f. Check the flame and spark rod. Clean and adjust if necessary.
- g. Inspect the burner carefully. Clean, adjust, and replace if necessary.
- h. Check voltages and amp draw on all motor(s).
- i. Check the operation of all gas safety controls individually.
- j. Check the operation of the automatic gas shut off valves and check them for leakage at the pressure test ports provided.
- k. Inspect combustion chamber for flame impingement. If there is evidence of flame impingement a complete burner adjustment must be made.

6. Off Season or Yearly

- a. Complete the monthly and quarterly maintenance schedule.
- b. Inspect all fan(s), wheels, housings and motors. Clean if necessary.
- c. Check that all fan blades, fan wheels, sheaves, and couplings are securely set on the shaft.
- d. Inspect all bearings and alignment. Adjust if necessary.
- e. Inspect all V-belts, sheaves, and coupling inserts. Replace if necessary.
- f. Inspect all electrical components, connections and terminals. Clean and tighten where necessary.
- g. Test ignition spark. Adjust gap if necessary.
- h. Clean ignition electrodes and check for cracks.
- i. Test ignition control and replace components if necessary.
- j. Inspect all regulators, relief valves, motorized valves, solenoid valves, vent valves, manual shut off valves and safety shut off valves. Check their operation and clean as necessary.
- k. Ensure all vents to the atmosphere are clean and free from obstruction.
- l. Inspect and clean all drip legs in the fuel line.
- m. Lubricate fan motor as directed by motor manufacturer.
- n. Inspect all motor wiring for loose connections.
- o. Lightly oil all door latches.
- p. **Check that the battery on the (UC-01) has 3 VDC. Do not remove or replace the battery with the power turned off to the control.**
- q. Check all nuts and bolts for tightness.

NOTE: Keep screened air intakes clear of obstructions at all times.

- r. Check the condensate lines for any leaks or blockage.
- s. Inspect the combustion chamber and vent for any signs of carbon deposits, soot or scale. Clean if necessary.

Lubrication Instructions

Item	Manufacturer	Bearing Type
All 3 phase fan motors (1 HP to 100 HP) ODP, TEFC <i>Recommendation: See following note.</i>	US., Baldor or equal	Single row ball bearings
All 1 phase motors (Fractional HP) ODP, TEFC or TEAO <i>Recommendation: See following note.</i>	Century, G.E., or equal	Bronze sleeve bearings
Fractional HP single phase, ODP or TEFC <i>Recommendation: See following note.</i>	Century, G.E. or equal	Bronze sleeve bearings
Fan shaft bearings <i>Recommendation: See following note.</i>	Fafnir or equal	Self-aligning single row or double row ball bearings, resilient mounted
Dampers <i>Recommendation: See following note.</i>	Factory or equal	Sleeve

1. Blower Motors – Some motors require lubrication while others do not. Those that require lubrication can be identified by the presence of grease plugs in the motor casing at each end. Motors that do not have grease plugs cannot be greased and are lubricated for the life of the motor bearing.

Lubrication of motors should be done while the motor is warm and at a standstill. Remove and clean all grease plugs and insert a grease fitting in the upper hole in the motor casing at each end. (Viewed as if motor were sitting horizontally on its base). There may be one or two plugs in each end casing of the motor. Add a small amount of a clean, good grade ball bearing grease, such as Exxon Polyrex EM or equal, with a low pressure grease gun. Run the motor five minutes before removing the grease fittings and replacing the plugs.

CAUTION: An excess of grease will overheat the bearings.

NOTE: On totally enclosed fan cooled (TEFC) motors, the rear end fan housing must be removed to expose the grease plugs.

2. Pillow Block Bearings – Pillow block bearings are used on supply blower(s). Bearings have been pre-lubricated with a number 2 lithium base grease. Relubrication should be done with a similar grease using a low pressure grease gun. Wipe all grease fittings clean before adding grease. Grease should be added slowly, in small amounts at frequent intervals while the shaft is being manually rotated.

A slight showing of grease at the seals with accompanying normal bearing temperature indicates proper lubrication. Normal temperature can range from “cool” to “hot to the touch” depending on size, speed and surrounding conditions. Excessive bearing temperature indicates faulty lubrication. An insufficient amount of grease is suggested by a bearing showing no grease at the seals, and a higher than normal temperature and noise level. Excessive leakage of grease at the seals, and a high operating temperature suggest too much grease.

Frequency of Lubrication – Frequency of lubrication depends upon operating conditions. The bearing operating temperature is the best index for determining a relubrication schedule. The following chart gives the frequency of relubrication based upon continuous operation for various operating temperatures and can be used as a satisfactory guide for determining when all ball and roller bearings should be relubricated.

Speed	Temperature	Cleanliness	Interval
100 RPM	Up to 125°F	Clean	6 months
500 RPM	Up to 150°F	Clean	2 months
1000 RPM	Up to 210°F	Clean	2 weeks
1500 RPM	Over 150°F	Clean	weekly
Any Speed	Up to 150°F	Dirty	1 week to 1 month
Any Speed	Over 150°F	Dirty	daily to 1 week
Any Speed	Any Temp.	Very Dirty	daily to 1 week
Any Speed	Any Temp.	Extreme Conditions	daily to 1 week

Browning Bearing Set Screw Torque Values

Model#	Shaft Size	Torque (in-lbs)
Set Screw		
VPS-212	3/4	66 - 85
VPS-214	7/8	66 - 85
VPS-116	1	66 - 85
VF2S-116	1	66 - 85
VPS-219	1 3/16	66 - 85
VF4S-219	1 3/16	66 - 85
VPS-220	1 1/4	126 - 164
VPS-223	1 7/16	126 - 164
VPS-323	1 7/16	126 - 164
VF4S-227	1 11/16	126 - 164
VPS-327	1 11/16	228 - 296
VPS-231	1 15/16	228 - 296
VF4S-231	1 15/16	228 - 296
VPS-331	1 15/16	228 - 296
VPS-235	2 3/16	228 - 296
VF4S-235	2 3/16	228 - 296
VPS-236	2 1/4	228 - 296
VPS-239	2 7/16	228 - 296
VF4S-243	2 11/16	348 - 452
VPS-343	2 11/16	348 - 452
VPS-347	2 15/16	348 - 452
BOA Concentric		
VPB-231	1 15/16	220 - 240
VPB-331	1 15/16	220 - 240
Spherical Roller		
SPB 1000 NE	1 3/16	290 - 380
SPB 1000 NE	1 7/16	290 - 380
SPB 1000 NE	1 11/16	290 - 380
SPB 1000 NE	1 15/16	290 - 380
SPB 1000 NE	2 3/16	290 - 380
SPB 1000 NE	2 7/16	620 - 930
SPB 1000 NE	2 11/16	620 - 930
SPB 1000 NE	2 15/16	620 - 930
Sealmaster SleeveLoc		
SPB 2115 C2	1 15/16	65

When replacing bearings refer to the manufacturers installation instructions included with the bearing.

Typical Procedure For Changing The Shaft And Bearings

1. Remove protective shaft coating.
2. Remove the drive side sheave.
3. Disconnect the grease lines from the existing bearings.
4. Identify the total shim thickness at each bearing and mark the bearing mount for future reference.
5. Remove mounting bolts for bearings and remove any shims.
6. Loosen bearing and blower wheel shaft setscrews.

7. Remove the shaft from the unit by sliding the bearings and blower wheels along the shaft as the shaft is extracted. Unless a blower wheel is damaged, it should be unnecessary to remove the blower wheel from the blower housing.
8. Slide the new shaft through the first blower wheel hub.
9. Once the shaft is completely through the first blower wheel, slide a bearing onto this end of the shaft.
10. Slide the shaft through the next blower wheel hub and add another bearing. Continue this procedure until the shaft is through all of the blower wheels.
11. Place a bearing on each end of the shaft.
12. Replace the old shims with new.
13. Bolt the bearings in place and reattach the grease lines. (When installing a SleeveLoc bearing see note at bottom of page).
14. Adjust the shaft so the blower hub keyways are in the middle of the shaft keyways.
15. Adjust the shaft so it protrudes past the non-drive end bearing, the blower sheave keyway mates with the shaft keyway, and the drive side sheave can be aligned with the motor sheave. Ideally, the blower sheave should be as close to the drive side bearing as possible, the motor sheave should be as close to the motor housing as possible, and the belts should be straight.
16. Be sure the shaft does not rub on or interfere with the closing of the access door.
17. Align all bearing setscrews, so that the same set screw on each bearing is pointed in the same direction as the other bearings' setscrews.
18. Place a drop of "BLUE" Loctite on the bearing setscrews and tighten all of the setscrews. Follow the mounting instruction's procedure on the inside of the bearing box, for the proper tightening and torque values.
19. Align the blower hubs' keyway with those in the shaft. Be sure the clearance between the blower wheel and blower housing is the same on each side.
20. Rotate the shaft by hand to insure free operation. Correct any rubbing of the blowers on the housings.
21. Place a drop of "BLUE" Loctite on the blower setscrews and tighten all of the setscrews.
22. Align the blower and motor sheaves using a laser or straight edge and tighten the blower sheave to the shaft.
23. Replace the belts and tighten the motor base adjustment for the proper belt tension. Over tightening the belt tension will severely reduce belt and bearing life. Belt deflection should be approximately 1/64 inch of the belt span.

24. Monitor for excessive heat or vibration during operation.
25. All bearings are pre-lubricated and should not require greasing. Refer to the bearing manufacturer's instructions or the unit manufacturer's instructions for proper bearing maintenance.

Note: Drive side SleeveLock bearing installation (SPB-2115-C2).

1. **Mount all the bearings and leave all the bolts and setscrews loose**
2. **Tighten setscrews on SleeveLock bearing to the tightening pattern as described in the installation sheet that comes with the bearing to a final 65 inch lbs while rotating the shaft. Check to make sure the insert of the bearing is centered in the bearing housing and then bolt bearing down.**
3. **Tighten down the bolts and setscrews on the remaining bearings per installation sheet starting from the end bearing back toward's the SleeveLock while rotating the shaft.**

3. Dampers – Dampers should be inspected monthly **(daily in icy weather)** for securely fastened linkages, and smooth operation. If dampers are binding or excessively noisy, then lubrication may be required. Place one drop of #20 wt. machine oil, silicone spray, graphite or equal on each blade bearing, and linkage ball joint. Do not over lubricate, and wipe any excess from the area. Be sure to note that dampers over 49 inches long have intermediate bearings which require lubrication.

4. Louvers – Louvers should be inspected monthly **(daily in icy weather)** to make sure they are clear and open.

C. Air Filters

All filter banks should be equipped with a manometer or differential pressure switch to indicate when the filters are dirty. Filters should be replaced when the differential pressure across them reaches the manufacturer's recommended final value. Dirty filter elements should be replaced with a clean element of the same type and size. In addition, the factory not only suggests, but insists, that air filters be **checked every 30 days (daily in icy weather)** and replaced with new filters (throw-away type) or cleaned (washable type) as required. Cleanable filters should be given new application of filter coating after washing to maintain optimum filter performance.

The frequency of cleaning and replacing air filters applies twelve months of the year, **where blowers are used for ventilation and heating.**

D. Belt Tensions and Adjustments

Belt tension is adjusted during the initial run-in and test periods at the factory. However, the belts are run as slack as possible to prevent excessive damage to the bearings, yet tight enough to prevent slippage.

It is necessary, therefore, to tighten all belts during the first few months of operation, and to **check for proper tension weekly during the first 60 days**, after which 30-day check intervals are sufficient.

NOTE: Turn off all power to the equipment before checking belt tensions.

CAUTION: Do not attempt to tighten any belt or belts by changing the pitch of an adjustable pulley, as this will change the speed of a driven pulley, causing the unit to be rendered OUT OF AIR BALANCE. Do not overtighten belts.

Suggested Belt Tension Method

1. Check tension frequently during the first 24-48 hours of run-in operation. Ideal tension is the lowest tension at which the belt will not slip under peak load conditions. Over tensioning shortens belt and bearing life.
2. To properly tension a conventional V-belt drive use the following procedure:
 - a. Measure the span length.
 - b. At the center of the span, apply a force perpendicular to the span to deflect the belt 1/64 inch for every inch of span length. For example, for a 40 inch span, apply a force that will deflect the belt 40/64 or 5/8 of an inch.
 - c. Compare the force you have applied with the values given in the table below. If the force is between the values for normal tension and 1-1/2 times normal tension, the belt tension should be satisfactory. If the belt tension is not within this range, it can be adjusted by loosening the motor mounting bolts, and adjusting the position of the motor along its base.

B Section

small pulley diameter range in Inches	Belt Manufacturer & Type Belt	Pounds Force for Normal Tension	Pounds Force for 1½ times Normal Tension
3.4-4.2	Gates Hi-Power	4.4	6.6
4.4-4.6	Gates Hi-Power	4.9	7.4
5.8-8.6	Gates Hi-Power	5.8	8.7

Note: For recommendation of other types of belts, consult respective manufacturers.

E. Coils And Related Items

1. Coils – Coil surfaces must be kept clean of dirt and lint in order to operate at rated efficiency. Coils should be inspected on a regular basis and cleaned as required.

CAUTION: Solutions used to clean coils must not be corrosive to metals or materials used in the manufacture of this equipment. If cleaning solutions are applied through means of high pressure spray, care must be taken to avoid damaging the coil fins.

2. Condensate Drain Pan – Periodically flush the condensate pan and drain system with a water hose.

F. Gaskets

Gaskets are used on doors, inspection covers, some filter racks, and some outdoor air dampers. Inspect gaskets periodically and repair or replace as required.

G. Caulking

Inspect cabinet and add caulking as required.

H. Casing

Periodic cleaning of the casing is recommended to remove dirt, grease and corrosive substances that may injure finish. Rusted or corroded areas should be cleaned and painted.

I. Support

Inspect the entire support structure to be sure everything is firmly in place.

J. Heater

1. At least a yearly inspection is recommended for heating installations and more frequently for process applications in year-round operation. Your own experience is the best guide in determining frequency of inspection, but as a minimum the following procedure should be followed:
 - a. Shut the system down totally, disconnecting or locking out power supply so there can be no accidental start-up during inspection.
 - b. Inspect the burner carefully, including upstream and downstream sides of mixing plates as well as burner body face. Note that complete burner assembly may have to be removed for proper inspection and cleaning. Any accumulation of scale or foreign material on either side of the mixing plates should be removed with a wire brush. Check visually that no holes in the mixing plates are blocked. If any burner ports are plugged (even partially) clear them with a piece of wire. See Maintenance of Gas Ports.

WARNING: Do not enlarge burner ports or performance may be drastically affected.

If any mixing plates are loose or missing fasteners, tighten/replace as necessary. Always use zinc plated or stainless fasteners. The mixing plates on the burner may display “hairline” cracks. These cracks are normal, and caused by thermal stresses occurring during combustion. The presence of these “hairline” cracks in no significant way affects the combustion efficiency or performance of the heater. Should a large opening develop, it may cause difficulties in cross ignition of flame across the face of the burner. If this does occur, the specific mixing plate or plates involved **must** be replaced.

2. Inspect the flame rod and ignition electrode for dirt and moisture. Wipe off if necessary. Examine for any evidence of premature arcing. If in doubt, check continuity of flame rod to be sure it is not grounding out. Replace if required.

The porcelain on the ignition electrode must be intact - not cracked. The spark gap should be 1/8 of an inch on Mestek burners.

3. Replace all access panels which have been removed. Put system back into operation and view burner while cycling through full firing range. This will give a visual check for blocked burner ports. Check for normal response and function of all controls.
4. Check all gas piping for possible leaks using a soap bubble solution.
5. Inspect the burner support means to be sure that everything is firmly anchored in place.
6. Check the CO level in the entering and leaving airstream of the furnace. If the CO level is greater in the leaving airstream, it is possible that the heat exchanger is leaking CO into the airstream. The leak must be located and repaired or replace the heat exchanger.

SECTION X - MESTEK LINE BURNERS

Inspection and Maintenance of Gas Ports

Conduct initial inspection within the first month after commissioning. Visually check the gas ports of new burner assemblies for any piping scale or debris. Use Pin Vise with drill bit to remove.

Annual inspections are normally adequate once the initial piping debris is removed. The operating conditions of the burner will determine how frequently maintenance is actually required.

Use of an electric drill motor is not suggested unless both Pin Vise and Drill can be chucked up in a vari-speed drill unit. Use caution, because it is easy to snap the bits off in a port when using a drill motor. Removal of broken bits from the gas ports is difficult.

Drill sizes that may be used in the field to clean out burner ports are shown below.

Heater Size	Drill Size
200 MBH Input (160 MBH Output)	5/64"
400 MBH Input (320 MBH Output)	7/64"
600 MBH Input (480 MBH Output)	7/64"

NOTE: When cleaning the two pilot orifices or removing the manifold end cap assembly be careful not to damage the flame pilot tip gasket.

P00117C - Mestek Line Burners

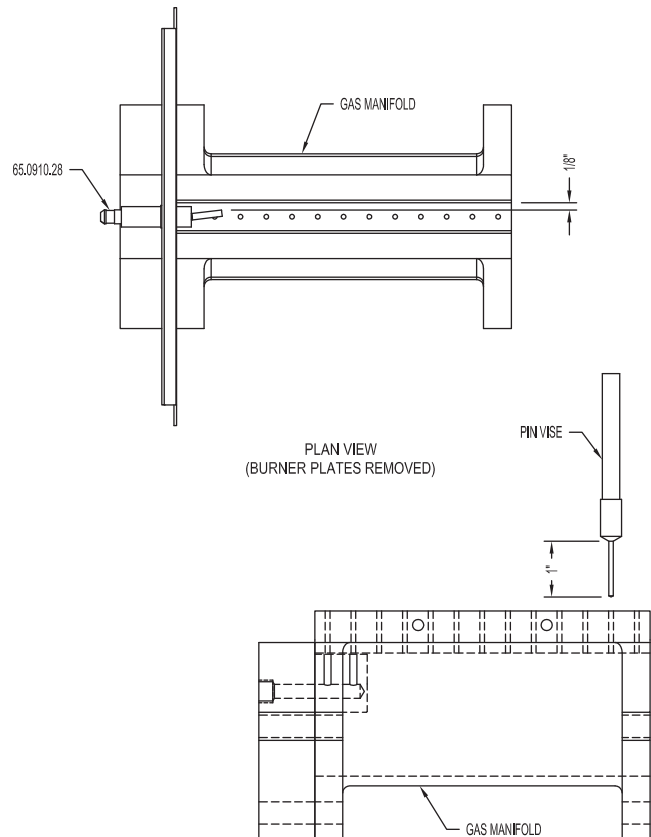
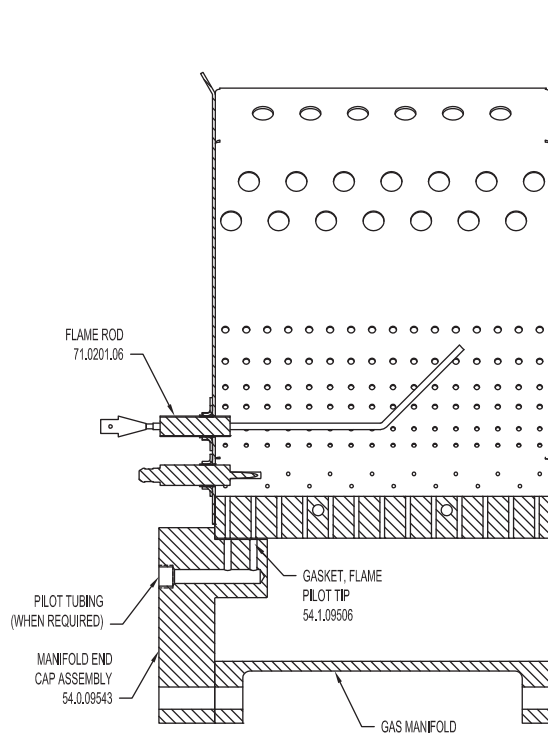

SECTION XI – CIRCUIT ANALYSIS, SEQUENCE AND BURNER SETUP, AND HIGH FIRE MANIFOLD ADJUSTMENT

CIRCUIT ANALYSIS – MODULATING GAS VALVE MOTOR

Connect a DC voltmeter (capable of reading 0-10 VDC) on the input terminals on Modulating Gas Valve Motor (MT-11).

The operation of the modulating gas valve motor with regard to voltage is as follows: For a furnace size 160 it is 2.65 to 10 VDC. For a furnace size 320 it is 2.65 to 10 VDC. For a furnace size 480 it is 0 to 10 VDC. With these voltages present the motor should be performing its modulating function, and the heater should be firing at a modulated flow rate between low and high fire, depending upon the voltage. At approximately 10 volts DC, the motor should be delivering full flow to the heater and the burner should be in high fire. If the DC voltage is obtained on the motor terminals, but the heater does not respond as described, the problem can be isolated to the motor itself or to the gas control manifold of the heater. (See the Troubleshooting Guide for replacement of motor).

If the proper voltages are not obtained and the wiring is correct the problem can be isolated to the electronics. (See the Troubleshooting section and the Digital Control User Manual).

CIRCUIT ANALYSIS – BURNER MOTOR

Connect a DC voltmeter (capable of reading 0-10 VDC) on the input terminals to Burner Blower Motor Control (BC-01).

The operation of the burner motor (MT-08) with regard to voltage is as follows: For a furnace size 160 it is 1 to 7.25 VDC. For a furnace size 320 it is 1 to 5 VDC. For a furnace size 480 it is 1 to 7.5 VDC. With these voltages present the burner motor should be performing its modulating function, and the motor should be running at a modulated flow rate between low and high speed, depending upon the voltage. At the highest volts DC, the motor should be delivering full airflow to the heater and the burner should be in high fire. If the DC voltage is obtained on the burner blower motor control input terminals, and the burner motor does not respond as described, the problem can be isolated to the motor itself, burner blower motor control, or the incoming power supply.

NOTE: With the incoming power applied and if the feedback signal wires are loose or disconnected the burner motor will run at maximum speed.

TACH MONITOR

The operation of the burner motor (MT-08) with regard to the minimum fan speed is accomplished with the tach monitor (TM-01). When voltage is applied the (green) power light will be illuminated. The (green) tach light will blink and a contact will close when the burner motor feedback signal indicates the motor is running at an acceptable speed. If the (red) fault light is illuminated with the burner motor running greater than 600 RPM, the problem can be isolated to the control itself or the burner motor feedback signal.

If the proper voltages are not obtained and the wiring is correct the problem can be isolated to the electronics. (See the Troubleshooting section and the Digital Control User Manual).

SEQUENCE AND BURNER SETUP

The I/O Zone 583 Controller (UC-01) must be calling for the burner to be enabled. The DO-2 light will be on and Burner Enable Relay (RE-28) needs to be energized. With the safeties, burner motor and tach monitor circuits made power will be applied to Burner Relay (RE-02). **If the outside air is above the Heating Economizer Setpoint 65° F the burner will be disabled.** You will need to disconnect the plug where the Outside Air Temperature Sensor (TS-01) and Discharge Air Temperature Sensor (TS-03) are wired to the I/O Zone 583 Controller (UC-01), (see High Fire Adjustment in following section). **Reconnect the plug if you are getting close to the Freezestat lockout time, which is approximately 3 minutes.** To reset the Freezestat alarm simply turn the power off and back on at the disconnect switch.

NOTE: A BACview or PC is required to change settings. See the Digital Control System User Manual for a more detailed sequence of operation.

HIGH FIRE MANIFOLD ADJUSTMENT

Prior to setting high fire you should have your test equipment installed and be familiar with the gas valve (VG-02) and its adjustment. Check to make sure the correct DC voltage is present at the input terminals to the (MT-11) Modulating Motor and (MT-08) Burner Motor (see Circuit Analysis – Modulating Gas Valve Motor and Burner Motor). The modulating motor should be fully open and the burner motor should be at full speed. Adjust the regulator on (VG-02) for the high fire setpoint, refer to the rating plate on unit for Normal Manifold Pressure in inches of w.c. The typical high fire flame should be blue and approximately 12 to 18 inches long with short orange to yellow tips. Ensure proper overfire draft in high fire at test port in heat exchanger is set per rating plate. After high fire has been set, low fire requires no further adjustment. Cycle the burner several times to be sure it lights off reliably.

SECTION XII - THERMISTOR OUTPUT CURVE

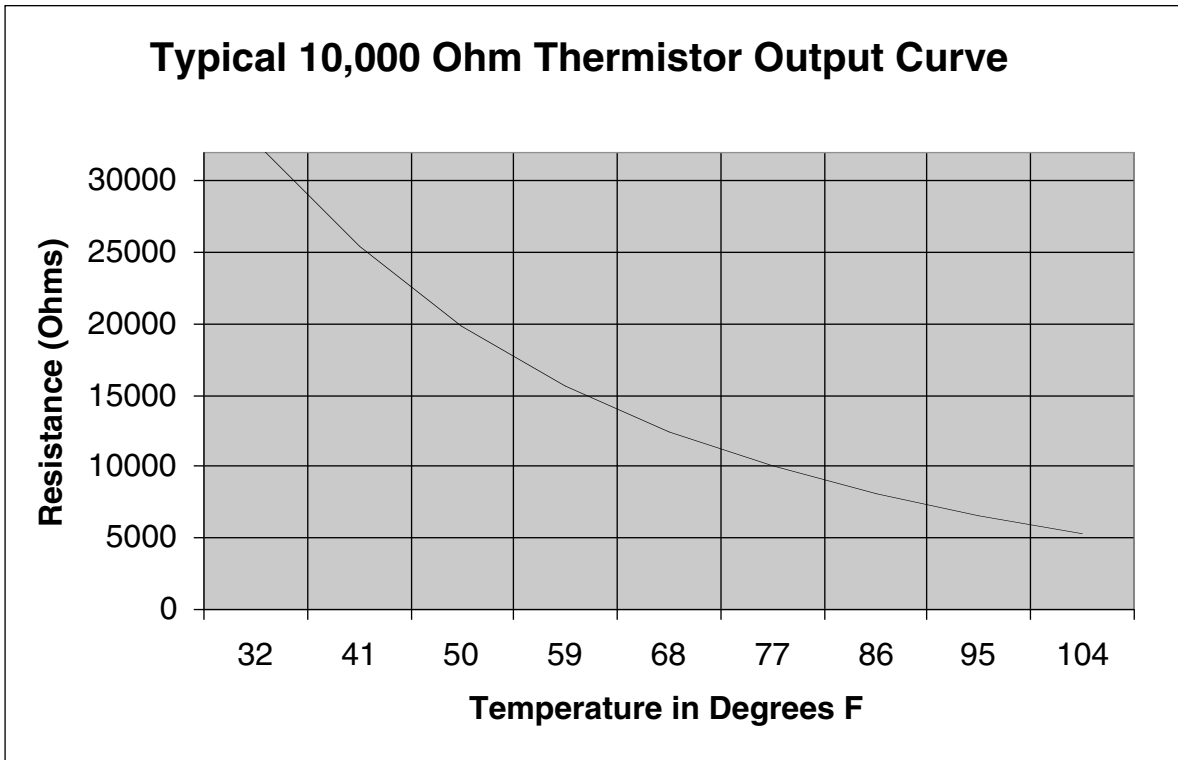

SECTION XIII - REPLACEMENT PARTS

Replacement parts may be ordered from the factory. All warranty parts will be shipped freight allowed from factory for normal ground service. Warranty parts must be returned prepaid within **30 days**. Credit will be issued if part is complete, defective and returned on time.

When parts are ordered, MODEL NUMBER, SERIAL NUMBER, FACTORY ORDER (F.O.) and PART NUMBERS are required. Belts, filters, and fuses are not covered under warranty.

Dealer/Contractor Name: _____

Address: _____

City: _____

State: _____ Zip: _____ Ph: _____



4830 Transport Drive, Dallas, TX 75247 Phone: 214-638-6010 Fax: 214-905-0806